

blink

User Manual



3rd Generation of Basic Charger-32A Revision 1.17

IMPORTANT SAFETY INSTRUCTIONS

This document contains instructions and warnings that must be followed when installing and using the Electric Vehicle Supply Equipment (EVSE). Before installing or using the EVSE, read this entire document as well as WARNING and CAUTION markings in this document.

Safety Instructions

The symbols used have the following meaning:



WARNING: RISK OF PERSONAL INJURY



WARNING: RISK OF ELECTRIC SHOCK



WARNING: RISK OF FIRE



CAUTION: RISK OF DAMAGE TO THE EQUIPMENT

- The charge point must be installed only by licensed electricians.
- Make sure that the materials used and the installation procedures follow local building codes and safety standards.
- The information provided in this manual in no way exempts the user of responsibility to follow all applicable codes or safety standards.
- This document provides instructions for the charge point and should not be used for any other product. Before installation or use of this product, review this manual carefully and consult with a licensed contractor, licensed electrician, or trained installation expert to make sure of compliance with local building codes and safety standards.

Repair and Maintenance Clause

- Only licensed electricians can repair or maintain the charge point. It is forbidden for general users to repair or maintain it.

- Turn off input power before repair or maintenance the charge point.

Federal Communication Commission Interference Statement

This device complies with Part 15 of the FCC Rules. Operation is subject to the following two conditions: (1) This device may not cause harmful interference, and (2) this device must accept any interference received, including interference that may cause undesired operation.

This equipment has been tested and found to comply with the limits for a Class B digital device, pursuant to Part 15 of the FCC Rules. These limits are designed to provide reasonable protection against harmful interference in a residential installation. This equipment generates, uses and can radiate radio frequency energy and, if not installed and used in accordance with the instructions, may cause harmful interference to radio communications. However, there is no guarantee that interference will not occur in a particular installation. If this equipment does cause harmful interference to radio or television reception, which can be determined by turning the equipment off and on, the user is encouraged to try to correct the interference by one of the following measures:

- Reorient or relocate the receiving antenna.
- Increase the separation between the equipment and receiver.
- Connect the equipment into an outlet on a circuit different from that to which the receiver is connected.
- Consult the dealer or an experienced radio/TV technician for help.

FCC Caution: Any changes or modifications not expressly approved by the party responsible for compliance could void the user's authority to operate this equipment.

This transmitter must not be co-located or operating in conjunction with any other antenna or transmitter.

Radiation Exposure Statement:

This equipment complies with ISSED radiation exposure limits set forth for an uncontrolled environment. This equipment should be installed and operated with greater than 20cm between the radiator & your body.

Industry Canada statement:

This device complies with ISSED's licence-exempt RSSs. Operation is subject to the following two conditions: (1) This device may not cause harmful interference, and (2) this device must accept any interference received, including interference that may cause undesired operation.

Le présent appareil est conforme aux CNR d' ISED applicables aux appareils radio exempts de licence. L'exploitation est autorisée aux deux conditions suivantes : (1) le dispositif ne doit pas produire de brouillage préjudiciable, et (2) ce dispositif doit accepter tout brouillage reçu, y compris un brouillage susceptible de provoquer un fonctionnement indésirable.

Radiation Exposure Statement:

This equipment complies with ISED radiation exposure limits set forth for an uncontrolled environment. This equipment should be installed and operated with greater than 20cm between the radiator & your body.

Déclaration d'exposition aux radiations:

Cet équipement est conforme aux limites d'exposition aux rayonnements ISED établies pour un environnement non contrôlé. Cet équipement doit être installé et utilisé à plus de 20 cm entre le radiateur et votre corps.



WARNING: RISK OF ELECTRIC SHOCK

When using electric products, basic precautions should always be followed, including the following. This manual contains important instructions that shall be followed during installation, operation and maintenance of the unit.

- Read all the instructions before using this product.
- This device should be supervised when used around children.
- Do not put fingers into the EV connector.
- Do not use this product if the flexible power cord or EV cable is frayed, has broken insulation, or any other signs of damage.
- Do not use this product if the enclosure or the EV connector is broken, cracked, open, or shows any other indication of damage.
- To avoid a risk of fire or electric shock, do not use this unit with an extension cord.



WARNING: RISK OF ELECTRIC SHOCK

Improper connection of the equipment grounding conductor can result in a risk of electric shock. Check with a qualified electrician or serviceman if you are in doubt as to whether the product is properly grounded.

Do not modify the plug provided with the product – if it will not fit the outlet, have a proper outlet installed by a qualified electrician.



WARNING: RISK OF ELECTRIC SHOCK

Do not remove the cover or attempt to open the enclosure. No user serviceable parts inside. Refer servicing to qualified service personnel.



WARNING: RISK OF ELECTRIC SHOCK

- Do not touch live electrical parts.
- Incorrect connections may cause electric shock.
- Do not Disconnect Under Load.



WARNING: This equipment is intended only for charging vehicles that do not require ventilation during charging. Please refer to your vehicle's owner's manual to determine ventilation requirements.



WARNING: Do not use extender cables to increase the length of the charging cable. Maximum length is limited to 25 feet by the National Fire Protection Agency.



WARNING: Do not drag the charge point by input power cord.



CAUTION: Do not expose to liquid, vapor or rain.



CAUTION: If this unit is installed outdoors, the outlet must be rated for outdoor installation. The outlet must be installed properly to maintain the proper NEMA rating of the enclosure.

- Installation work and electrical wiring must be done by qualified person(s) in accordance with all applicable codes and standards, including fire-rated construction.
- Do not touch the terminals or other current-carrying parts.
- Take care not to drill into any pipes or power lines beneath the surface during mounting holes preparation. Use power line / metal detector.
- Do not trample or drive over the product's cables.
- Do not put any foreign objects into the enclosure.
- Do not start the engine when the charging connector is still connected.



CAUTION: Do not use this product if there is any damage to the unit. Send the unit back to the manufacturer in the event the unit is not operational.

SAVE THESE INSTRUCTIONS

Contents

1	Introduction	8
1.1	Product view	8
2	Specifications	14
2.1	Product specifications.....	14
3	Installation	16
3.1	Before installation.....	16
3.1.1	Safety check	16
3.1.2	Grounding instructions	16
3.2	Tools & parts required for installation.....	17
3.3	Install the SIM card (for IC3 only)	17
3.4	Install the charge point	21
3.5	Input cord connection.....	25
3.6	Install the holster	28
3.7	Getting started (for SC3/IC3 only)	31
3.7.1	Setting up the local network.....	31
3.7.2	Log in	33
3.8	Web-page overview (for SC3/IC3 only).....	34
3.8.1	Menu overview	34
3.8.2	Configuration menu	35
3.8.3	Maintenance menu.....	36
3.8.4	EVSE Status.....	37
3.8.5	LLM Status menu.....	38

3.8.6	Security menu	39
3.9	Configuration (for SC3/IC3 only)	40
3.9.1	Factory settings	40
3.9.2	Station settings	41
3.9.3	OCPP settings	44
3.9.4	Communication settings	50
3.10	Maintenance (for SC3/IC3 only)	58
3.10.1	Reboot	58
3.10.2	Firmware upgrade	61
3.11	EVSE Status	62
3.12	LLM Status (for SC3/IC3 only)	63
3.12.1	LLM information	63
3.12.2	Gateway/Client group table	64
3.12.3	Operation mode	64
3.13	Security	73
3.13.1	Change password	73
4	Operations	74
4.1	Charging status indicators	74
4.2	Authorization (for IC3 only)	75
4.2.1	Online Authorization	75
4.2.2	Local Authorization	75
4.3	Charging an Electric Vehicle (EV)	76
4.3.1	Plug and Charge	76
4.3.2	RFID card (for IC3 only)	76
4.4	Stop charging	76
4.4.1	Interrupt charging	76

4.4.2	Auto restart	76
4.4.3	Power outage recovery	77
4.5	General care	77
4.6	Customer support	77

1 Introduction

This user manual applies to “32A Level 2 AC Charger for Plug-in Electric Vehicles (PEVs) and Battery Electric Vehicles (BEVs)”.

The Level 2 Electric Vehicle Supply Equipment (EVSE) with 32A capabilities will be used in North America. It can provide a shorter charging time than the traditional 16A EVSE.

!!! Any unauthorized modifications will void the manufacturer’s warranty. !!!

1.1 Product view

Different models of 3rd Generation of Charger:

Basic Charger-32A (BC3)



Figure 1-1 Front view

Box Contents

See the table for content differences of three models.

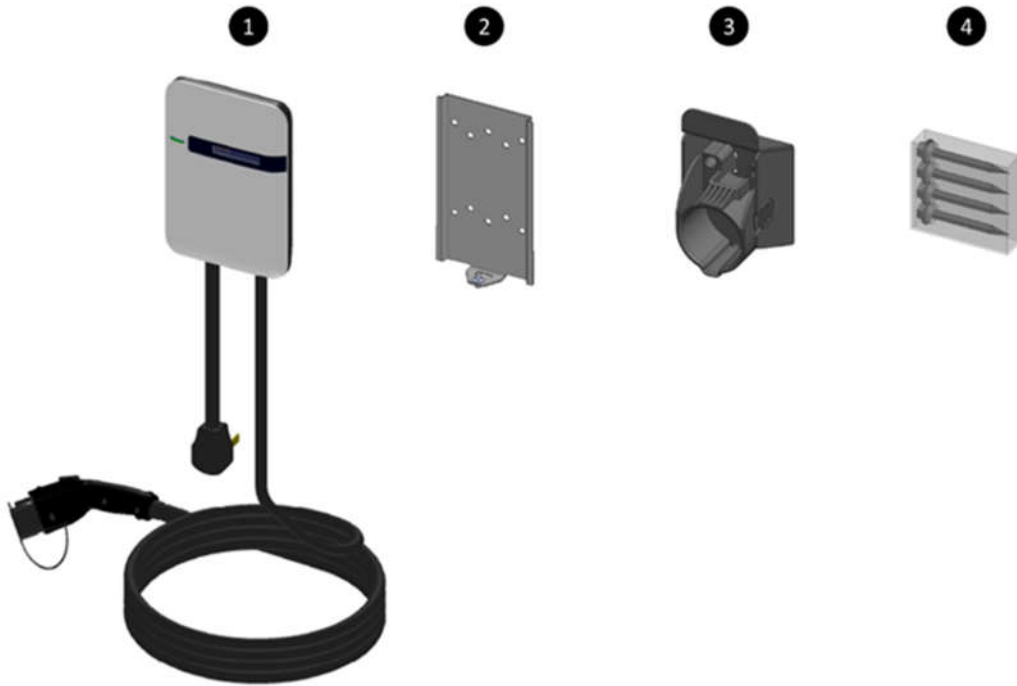

Figure 1-2 Box contents

Table 1-1 Accessories in the box

	Description	QTY	Remark
1	Basic Charger-32A (BC3)	1	<input checked="" type="checkbox"/> Charging Plug <input checked="" type="checkbox"/> Input Power Cord <input type="checkbox"/> OLED Display <input type="checkbox"/> RFID Icon
	Smart Charger-32A (SC3)		<input checked="" type="checkbox"/> Charging Plug <input checked="" type="checkbox"/> Input Power Cord <input checked="" type="checkbox"/> OLED Display <input type="checkbox"/> RFID Icon
	Intelligent Charger-32A (IC3)		<input checked="" type="checkbox"/> Charging Plug <input type="checkbox"/> Input Power Cord <input checked="" type="checkbox"/> OLED Display <input checked="" type="checkbox"/> RFID Icon
2	Mounting Bracket	1	Attached to the back of the charge point
3	Holster ASSY	1	With Hook x1, Holster x1 & M4xL15 tapping screw x2
4	Screw Bag	1	With #12xL50 tapping screw x4

Box Opening Process (Take Intelligent Charger-32A as example.)

1. Open the carton and remove the upper partition.



Figure 1-3 Opening the carton



Figure 1-4 Charge point device

2. Take out the charge point and upturn middle partition. The charging plug is in the bottom of the carton.



Figure 1-5 Take out the charge point



Figure 1-6 Charging plug

3. The hook and holster are placed inside the right of the middle partition.



Figure 1-7 Accessories inside the middle partition



Figure 1-8 Hook and holster

4. Release the bottom screw, then the wall mounting bracket can be removed.



Figure 1-9 Release the screw



Figure 1-10 Remove the mounting bracket

2 Specifications

2.1 Product specifications

(Note: Certification in process)

Table 2-1 Product specifications

Item	BC3	SC3	IC3
Application	Residential	Residential	Commercial
Voltage (Vac)	208/240VAC, Single Phase		
Frequency (Hz)	60 Hz		
Current (Rms)	32 A		
Charging Connector	SAE J1772 Type 1		
Charging Cable Length	25 ft. (18 ft. optional)		
Metering Accuracy	N/A	Embedded \pm 3%	
Real Time Clock	N/A	Yes (7 days)	
Protection	Over Voltage, Under Voltage, Surge Protection, GM/I, CCID20, Over Current, Over Temperature, Under Temperature, Short Circuit, Relay Malfunction/Welding Protection		
Indication	<ul style="list-style-type: none"> • Green Steady: Ready • Green Flashing (Fast): Authorized, wait for EV Connect • Green Flashing (Slow): Suspend (Occupying) • Blue Flashing (Slow): Charging • Red Steady: Unrecoverable Fault • Red Flashing (Slow): Recoverable Fault • Yellow Steady: Out of Service • Yellow Flashing (Slow): Booting / Firmware Upgrading <p><u>Remark</u></p> <ul style="list-style-type: none"> • Fast Flash: On Time 300ms, Off Time 200ms, 2Hz • Slow Flash: On Time 1200ms, Off Time 800ms, 0.5Hz 		
Wi-Fi	N/A	802.11 b/g/n	
Cellular	N/A		LTE Cat. 1 (AT&T or Verizon)
RFID	N/A		ISO 14443 A/B, ISO 15693, NFC, NEMA interoperability protocol
Display	N/A	116(L)*8.5(W)*37(H)mm, 5.57mm CHARACTER HEIGHT, 5*8 DOT MATRIX, OLED 20x2	
Data Protocol	N/A	OCPP 1.6	
Operation Temp.	-30 ~ 50 °C / -22 ~ 122 °F		
Storage Temp.	-40 ~ 70°C / -40 ~ 158 °F		
Mounting Type	Wall mount / Pole mount (optional)		
Wiring Type	NEMA 6-50		Hard-wired

Item	BC3	SC3	IC3
IP Performance	NEMA 4		
Impact Resistance	IK10		
Dimension (H x W x D, inch)	11.14" x 7.56" x 3.11"		
Web Portal Management	N/A	Yes	
Console Management	Yes		
Certification	UL 1998/2231/2594 FCC Part 15B		
	N/A	FCC Part 15.225 (RFID 13.56MHz) FCC Part 15.247 (WLAN 2.4GHz)	
	N/A		FCC Part 27 (AT&T) or FCC Part 27 (Verizon) Energy Star

3 Installation

3.1 Before installation

3.1.1 Safety check

- Check for transport damages.
- Before connecting the product to the power supply, check that the power supply voltage and current rating corresponds with the power supply details shown on the product rating label.



CAUTION: Disconnect the power supply before installing or repairing the charge point. Failure to do so may result in physical injury or damage to the power supply system and the charge point.



CAUTION: Avoid touching or pressing the OLED screen all times, as this may result in damage to the OLED screen.



DANGER: RISK OF SUFFOCATION

Keep any packing materials away from children – these materials are a potential source of danger, e.g. suffocation.

The charge point must be installed only by a licensed electrician in accordance with the provisions of the local electrical industry construction and should comply with national electrical codes and standards.

Before installing the charge point, make sure you have read all of these instructions in this manual and fully understand its contents.

Appropriate protection is required when connecting to a main switchboard. The tools and parts used as outlined in the section “Tools & parts required for installation”.

3.1.2 Grounding instructions

The charge point must be implemented equipment grounding through a permanent wiring system or an equipment grounding conductor. Use a wire with a dedicated grounding wire and a ring terminal and connected to the equipment ground terminal block for grounding.

3.2 Tools & parts required for installation

Table 3-1 Tools & parts required for installation

Tool	QTY	Model	Size	Supplier	Remark
Mounting Bracket	1	All	194x109x9 mm	Model Accessories	Fasten charge point to the wall
Holster ASSY	1	All	58x58x70 mm	Model Accessories	Hold EV charging plug
Screw	4	All	Tapping: #12	Model Accessories	Fasten Mounting Bracket & Hook
			Mechanical: M6	Commercially Available	
Wire, Copper	3	IC3	8 AWG	Commercially Available	UL1015 (recommended)
Heat Shrink Tube	3	IC3	For 8 AWG wire	Commercially Available	Protect wires & terminals
Terminal	3	IC3	For 8 AWG wire	Commercially Available	Connect input wires to the terminal block
Conduit	1	IC3	1 inch	Commercially Available	Protect power cable
Torx Screwdriver	1	All	T20	Commercially Available	
Philips Screwdriver	1	All	PH3	Commercially Available	
Hexagon Socket	1	All	5/16	Commercially Available	Tighten #12 Tapping screws
Torque Wrench	1	All	35 kgf-cm min	Commercially Available	

3.3 Install the SIM card (for IC3 only)

1. Disassemble top cover

1-1 Loosen the star screws (x5).

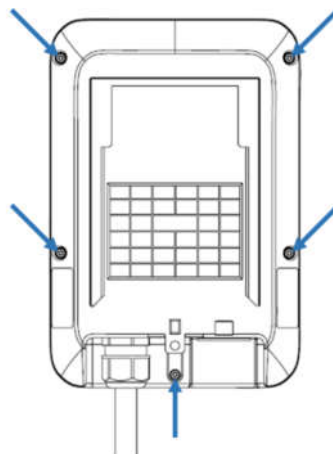

Figure 3-1 Five screws in the Base Cover position

2. Find SIM card socket

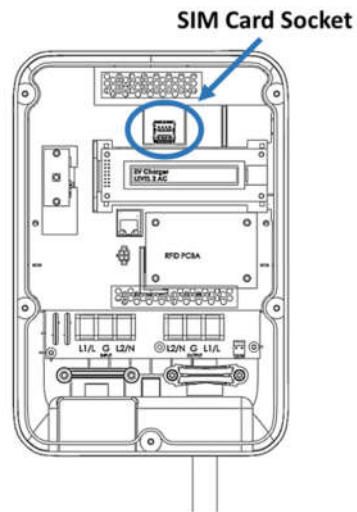

Figure 3-2 Position of SIM card socket

3. Insert SIM card

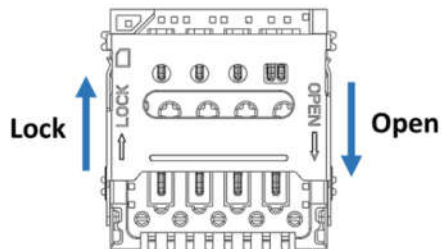

Figure 3-3 SIM card socket and cover Open/Close direction

3-1. Push down the cover to open SIM card socket.

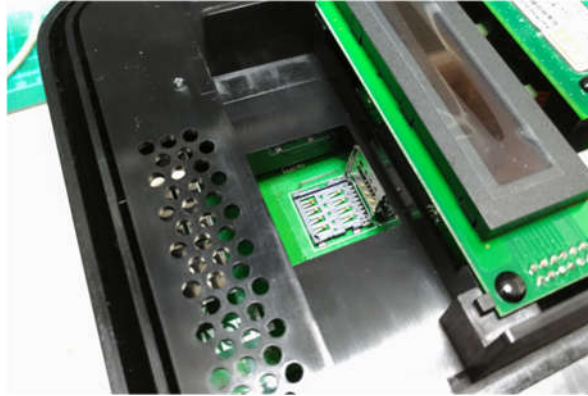

Figure 3-4 Open SIM card socket

3-2. Prepare the SIM card. (Use micro-SIM, 15mm x 12mm.)



Figure 3-5 Prepare the SIM card

3-3. Insert the SIM card.

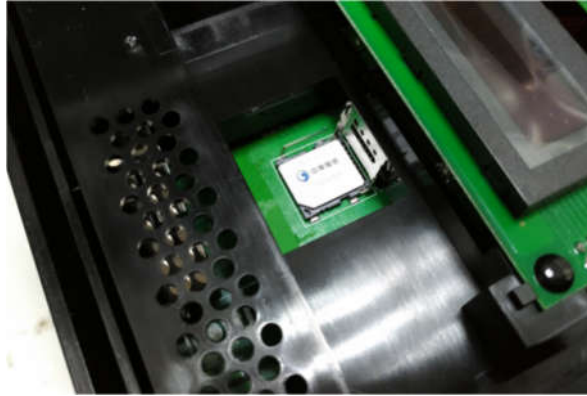

Figure 3-6 Insert the SIM card

3-4. Close the SIM card socket and push the cover toward lock direction to lock the cover.

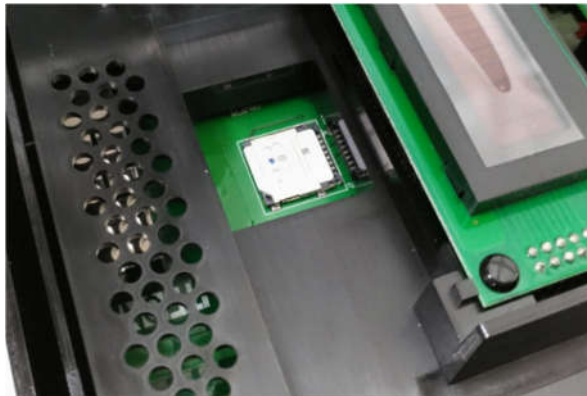

Figure 3-7 Lock SIM card socket cover

3-5. Reassemble the top cover. Please refer to the following torque. SIM card installation is completed.

Screw	Torque	
M4	16 kgf.cm	13.88 lb-in

3.4 Install the charge point

1. **Secure the main body mounting bracket to the wall with appropriate screw.**



DANGER: Disconnect power at the circuit breaker before installation.



CAUTION: Before mounting determine the suitable mounting location. The unit must be fixed to a wooden or masonry/concrete wall using hardware that is appropriate for the surface. Do not install on drywalls, wall boards or thin plywoods. The fixing point must be capable of supporting the weight of the unit.

Follow applicable accessibility requirements for the mounting position. The unit shall be stored or located at a sufficient height.

For indoor use: The unit shall be mounted at a sufficient height from the floor between 18 inches (450 mm) and 4 feet (1.2m).

For outdoor use: The unit shall be mounted at a sufficient height from the floor between 24 inches (600 mm) and 4 feet (1.2m).

The mounting bracket has ten screw holes. If only two screws be used to fasten the mounting bracket, the screws should pass through the middle two screw holes of the mounting bracket. The other screw holes are reserved for the user.

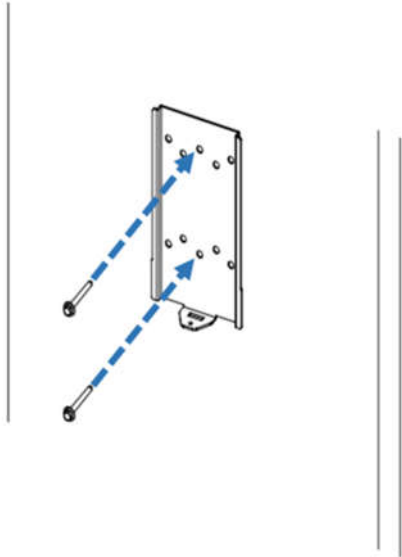

Figure 3-8 Fixing mounting bracket

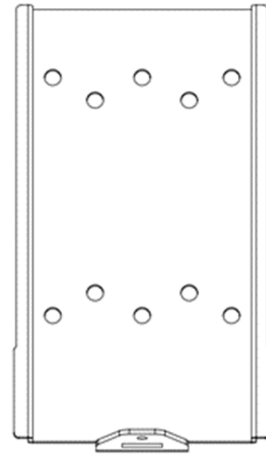

Figure 3-9 Screw holes of mounting bracket

Screw suggestion:

- a. For masonry walls, use M6 mechanical screws. (Commercially available)
- b. For finished walls supported by wood studs, use 1/4" or M6 tapping screws. (Commercially available)
- c. Please use following torque force.

Screw	Torque	
M6	25 kgf.cm min	21.7 lb-in min
#12	25 kgf.cm min	21.7 lb-in min

2. Mount charge point onto mounting bracket and lock the screw.

- 2-1. Put the charge point on the mounting bracket.
- 2-2. Fix charge point on mounting bracket by M4 screw and screw washer.
- 2-3. Please refer to the following torque.

Screw	Torque	
M4	16 kgf.cm	13.88 lb-in

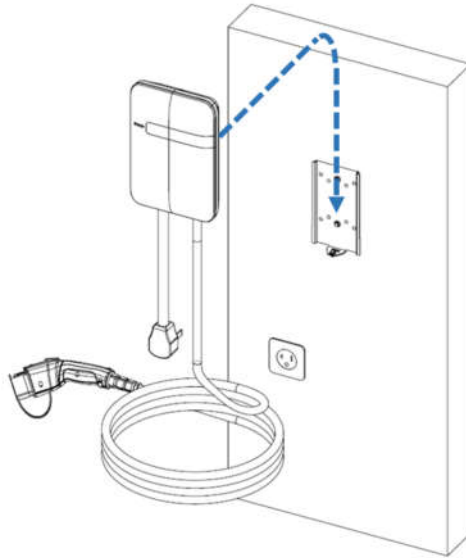

Figure 3-10 Charge point and mounting bracket

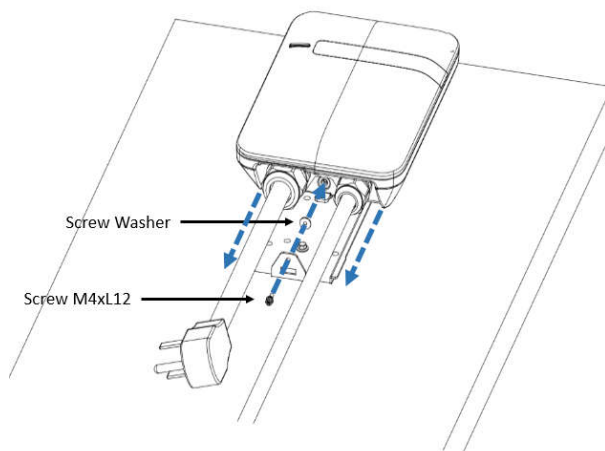

Figure 3-11 Screw locking position

3. Plug in the power cord. (BC3/SC3 ONLY)

The outlet should be located at 20-26 inch from the ground. Refer to the installation template to decide where to install the charge point.

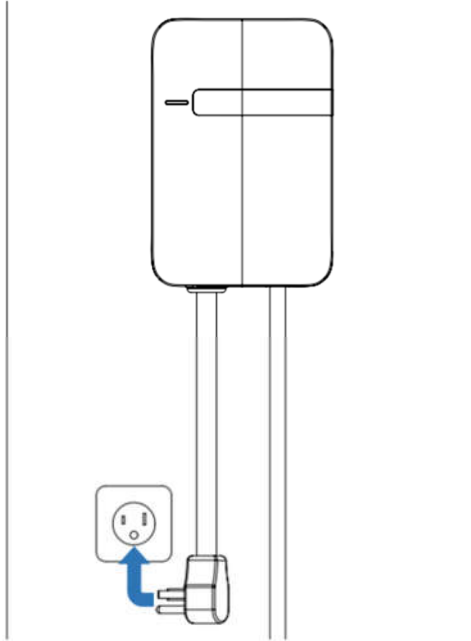

Figure 3-12 Plug in the power cord

3.5 Input cord connection

1. Choose the appropriate conduit in accordance with all applicable state, local and national electrical codes and standards.

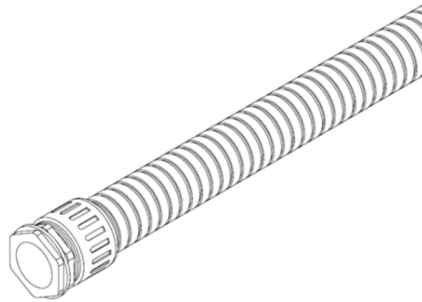

Figure 3-13 Conduit.

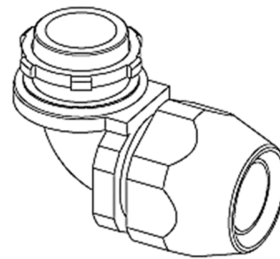

Figure 3-14 Right angle conduit

2. Clamp copper terminal to connect copper wire. The clamp point is covered by heat shrink tube for protecting.

2-1 Refer to the following wire specification. Use conductor type other than RHH, RHW and RHW-2 with outer covering.

Model	Terminal	Conductor	Rating
Intelligent Charger-32A	L1, L2, G	8 AWG	90C copper wire



Figure 3-15 Copper terminal, heat shrink tube and copper wire.

3. Electrical wiring to the charge point.

3-1. Disassemble top cover.

3-2. Use Philips screwdriver to release terminal screws.

3-3. Fold the wire end to pass through the conduit and insert them into the input hole.

3-4. Fix the copper wire on the corresponding terminal block. The wiring instruction is printed in front of the terminal block (L1/L2/G).

3-5. Use the following torque to connect the wire terminal to the terminal block.

Screw	Torque	
M4	16 kgf.cm	13.88 lb-in

3-6. The recommended terminal specifications are as following.

Terminal	Dimension(mm)
W	≤ 9.5
d2	4-6.4

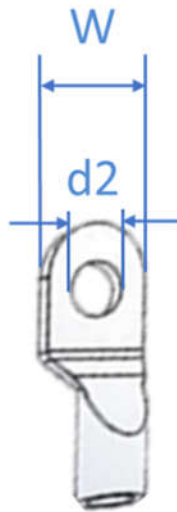

Figure 3-16 Dimension of terminal

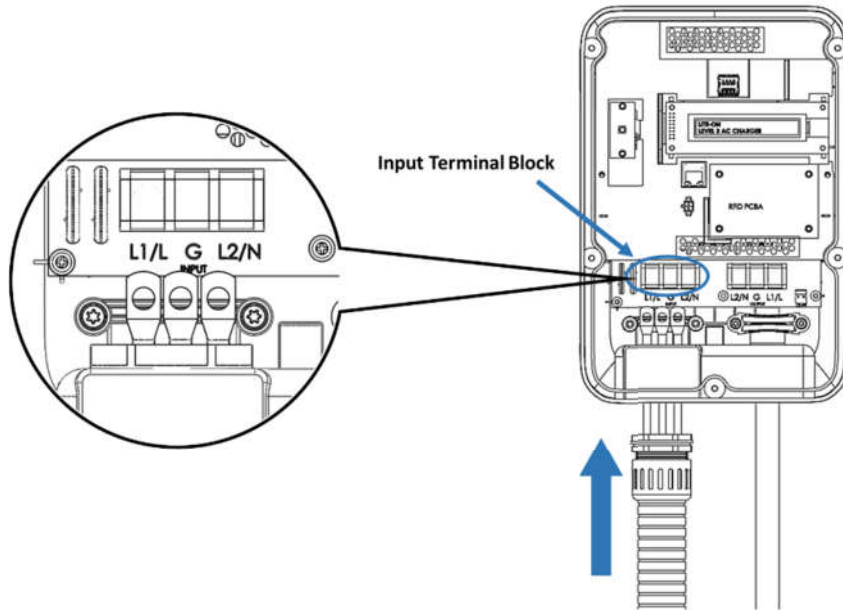

Figure 3-17 Input wiring



CAUTION: To reduce the risk of fire, connect only to a circuit provided with 40 amperes maximum branch circuit overcurrent protection in accordance with the National Electrical Code, ANSI/NFPA 70, and the Canadian Electrical Code, Part I, C22.1.



CAUTION: If this unit is installed outdoors, the outlet must be rated for outdoor installation. The outlet must be installed properly to maintain the proper NEMA rating of the enclosure.

Model	Current Rating
Intelligent Charger-32A	32 A

3-7. Lock the conduit on the enclosure. Please refer to the following torque.

Conduit	Torque	
1 "	35 kgf.cm	30.36 lb-in

3-8. Reassemble top cover. Please refer to the following torque.

Screw	Torque	
M4	16 kgf.cm	13.88 lb-in

3.6 Install the holster

1. Separate the holster from hook.

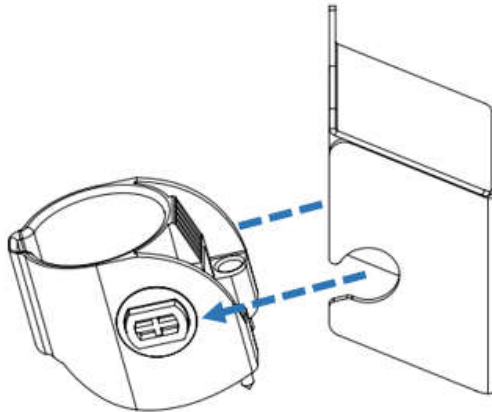

Figure 3-18 Separate the holster

2. Fasten the hook on the wall with appropriate screws.

2-1. For finished walls supported by wood studs, use #12 tapping screws (x2).

2-2. The recommend torque is 25 kgf.cm (21.7 lb-in).

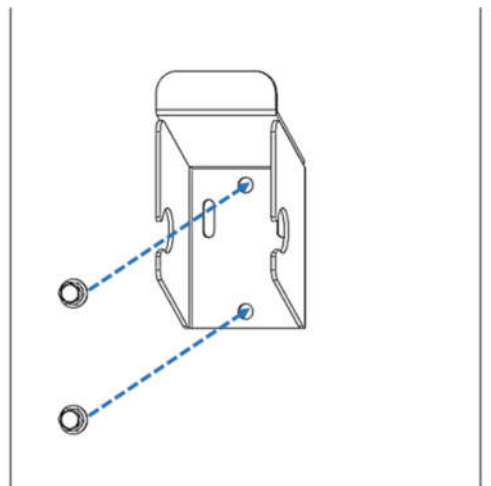

Figure 3-19 Secure the hook

3. Make the holster face up and combine with the hook.

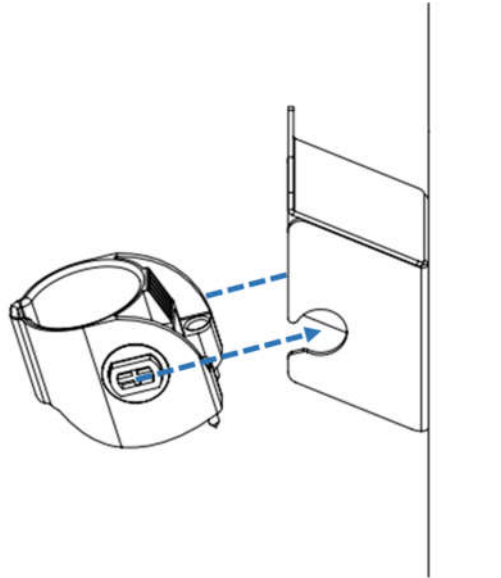

Figure 3-20 Secure the holster

4. Rotate the holster down totally.

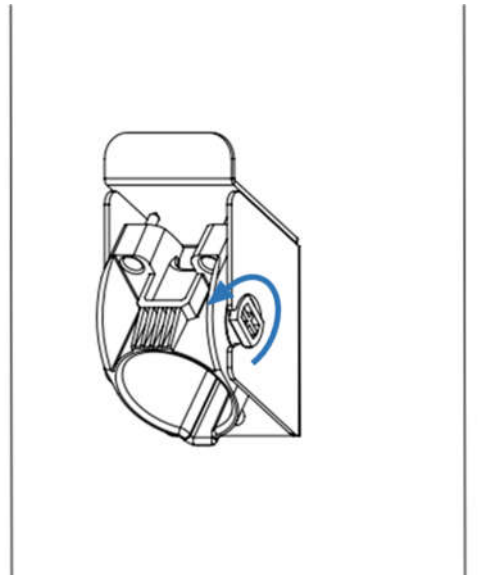

Figure 3-21 Rotate the holster

5. Keep the holster in this state and tighten screws completely.

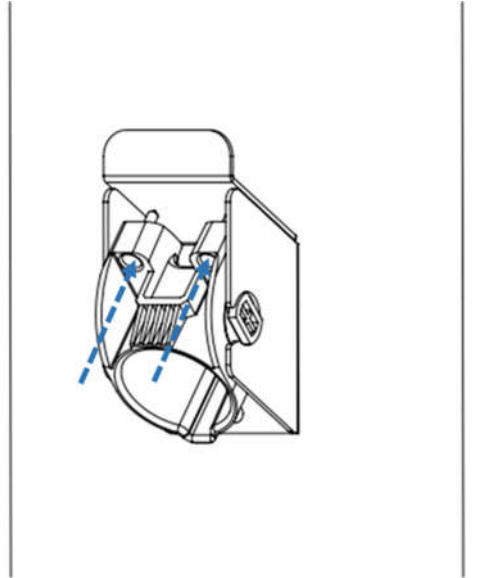

Figure 3-22 Lock screws

6. Place EV charging plug on the holster.

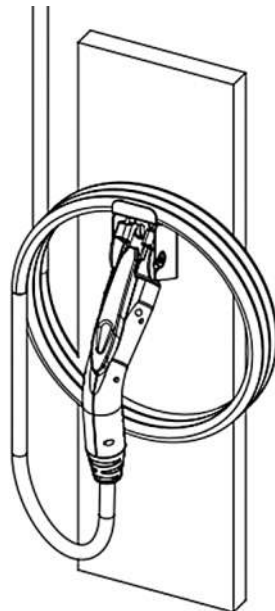

Figure 3-23 Place EV charging plug.

3.7 Getting started (for SC3/IC3 only)

3.7.1 Setting up the local network

First, connect a computer to the charge point using an Ethernet cable.



Figure 3-24 Location of Ethernet RJ-45 port

Secondly, set up a dynamic IP Address on your computer. For windows system, choose “Obtain an IP address automatically” in Internet Protocol Version 4 (TCP/IPv4) Properties dialog like the following figure.

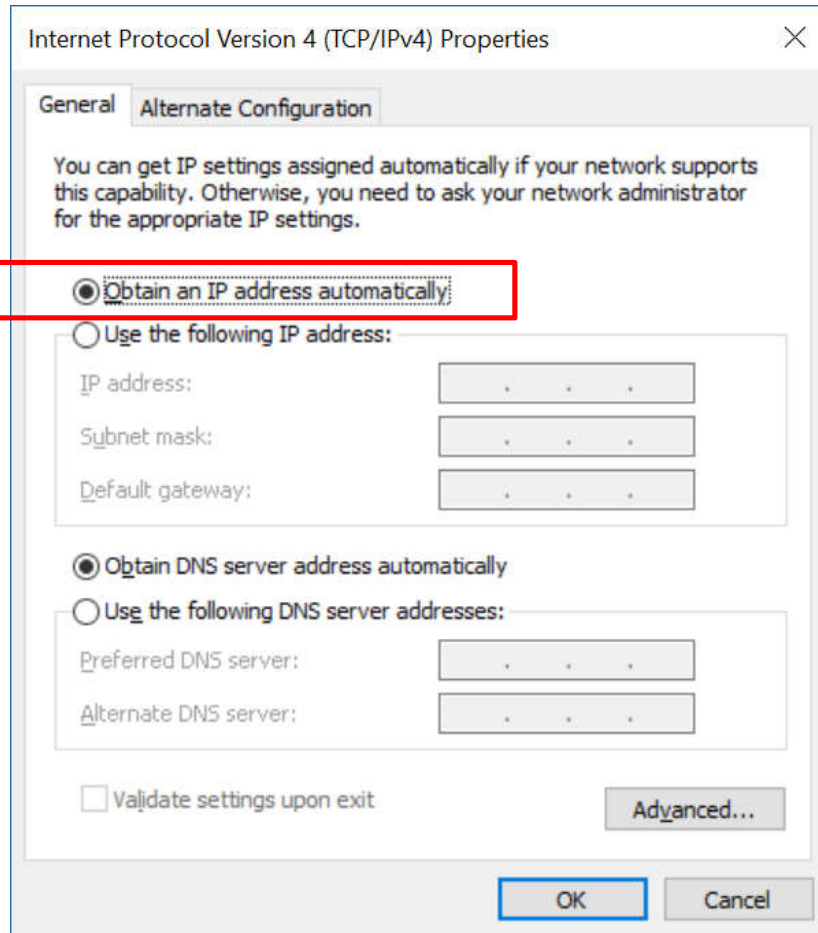

3.7.2 Log in

Open a web browser (Internet Explorer for example) and enter the IP address of SC3/IC3. Please enter the text below in the address field of the browser and press enter.

<http://192.168.199.1> If “Netwrok Mode” is Gateway and “Group Use External Gateway” is No.

or

<http://192.168.100.1> Any other “Netwrok Mode”.

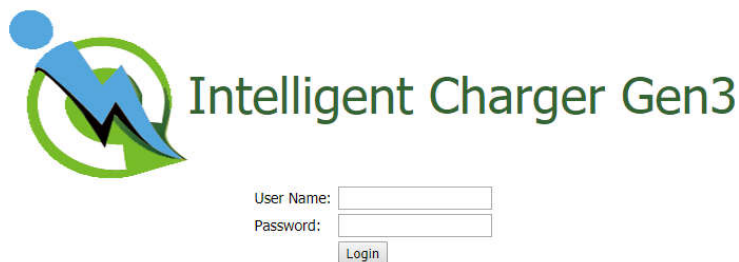

Now you should see the login screen:

To be able to configure the charge point you should enter “**admin**” in the user name box. The default password is “**howru2RU2IC3**”.

3.8 Web-page overview (for SC3/IC3 only)

3.8.1 Menu overview

To navigate via the web browser, use the menu items available: Configuration, Maintenance, EVSE Status, LLM Status, and Security.

The screenshot displays the web interface for a Blink charging station. On the left is a vertical menu with the following items: Configuration, Maintenance, EVSE Status, LLM Status, and Security. A callout box labeled "Menu List" points to this menu. The main content area shows the "Factory Settings" tab selected, with sub-tabs for "Station Settings", "OCPP Settings", and "Communication Settings". The "Basic Information" section contains the following data:

Basic Information	
Charge Point Vendor:	LITE-ON
Charge Point Model:	EX-1762-1A31
Charge Point Serial Number:	EX-1762-1A31-18-13-EM003
Hardware Version:	07.02-03.01
Firmware Version:	V1.00.34 (BBOX: V1.22) Kernel: 3.18.44 1407b
Meter Type:	Built-in meter
Reader Type:	Built-in RFID
DSMR Type:	Not Support
Production Date:	2018-03-29

The "Charging Connector Information" section contains the following data:

Charging Connector Information	
Number of Connectors:	1
Connector Type:	SAE J1772
Max Amperage Connector:	32.0 Amps

In the top right corner of the interface, there is a "Logout" button, which is pointed to by a callout box labeled "Logout button".

3.8.2 Configuration menu

When you choose the **Configuration** menu, a sub menu will appear:

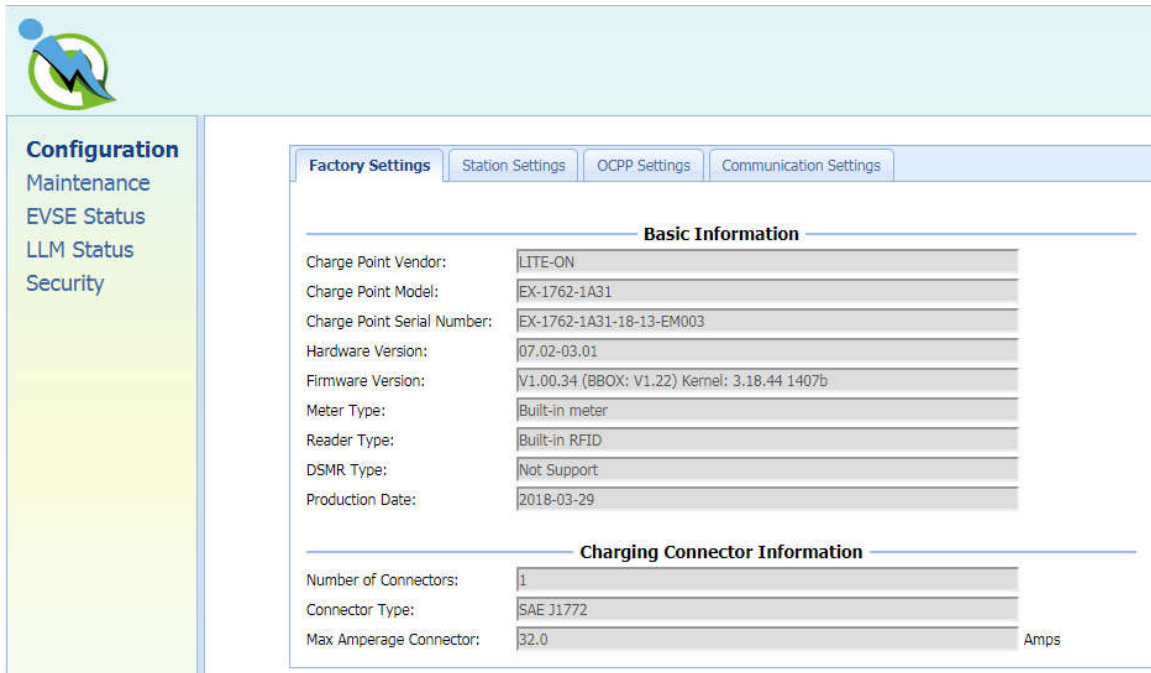

The screenshot shows a web interface for configuring a charge point. On the left is a navigation menu with 'Configuration' selected. The main area has four tabs: 'Factory Settings', 'Station Settings', 'OCPP Settings', and 'Communication Settings'. The 'Factory Settings' tab is active and displays two sections: 'Basic Information' and 'Charging Connector Information'. Each section contains a list of fields with their corresponding values.

Basic Information	
Charge Point Vendor:	LITE-ON
Charge Point Model:	EX-1762-1A31
Charge Point Serial Number:	EX-1762-1A31-18-13-EM003
Hardware Version:	07.02-03.01
Firmware Version:	V1.00.34 (BBOX: V1.22) Kernel: 3.18.44 1407b
Meter Type:	Built-in meter
Reader Type:	Built-in RFID
DSMR Type:	Not Support
Production Date:	2018-03-29

Charging Connector Information	
Number of Connectors:	1
Connector Type:	SAE J1772
Max Amperage Connector:	32.0 Amps

- The “**Factory Settings**” tab is used to display the information of the charge point.
- The “**Station Settings**” tab is used to set up the configuration regarding to the charge point itself.
- The “**OCPP Settings**” tab is used to set up the custom properties for uses in OCPP 1.6 services.
- The “**Communication Settings**” tab is used to set up the network connection and load management.

3.8.3 Maintenance menu

When you choose the **Maintenance** menu, a sub menu will appear:

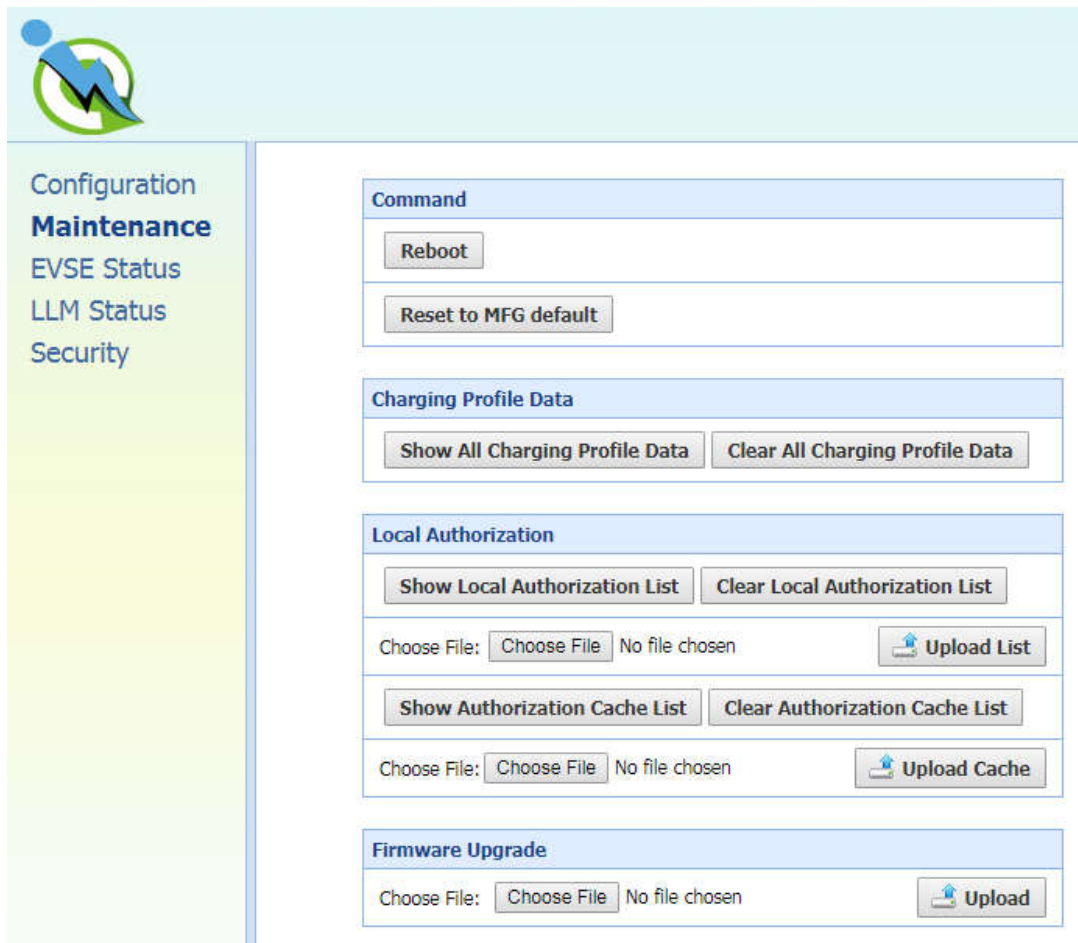

- The “**Command**” screen can be used to restart the charge point and reset settings to Manufacturing default.
- The “**Charging Profile Data**” screen can be used to show and clear charging profiles including “Charge Point Max Profile”, “Tx Default Profile” and “Tx Profile”. Charging Profile is defined in OCPP 1.6 specification.
- The “**Local Authorization**” screen can be used to display and clear the Local Authorization List and Authorization Cache List. Both lists are defined in OCPP 1.6 specification.
- The “**Firmware Upgrade**” screen can be used to upgrade the firmware of the charge point.

3.8.4 EVSE Status

When you choose the **EVSE Status** menu, a sub menu will appear:



- The “**Electric Vehicle Supply Equipment Status**” can be used to show the information of EVSE. Usually these information are only for diagnostic use.

3.8.5 LLM Status menu

When you choose the **LLM Status** menu, a sub menu will appear:

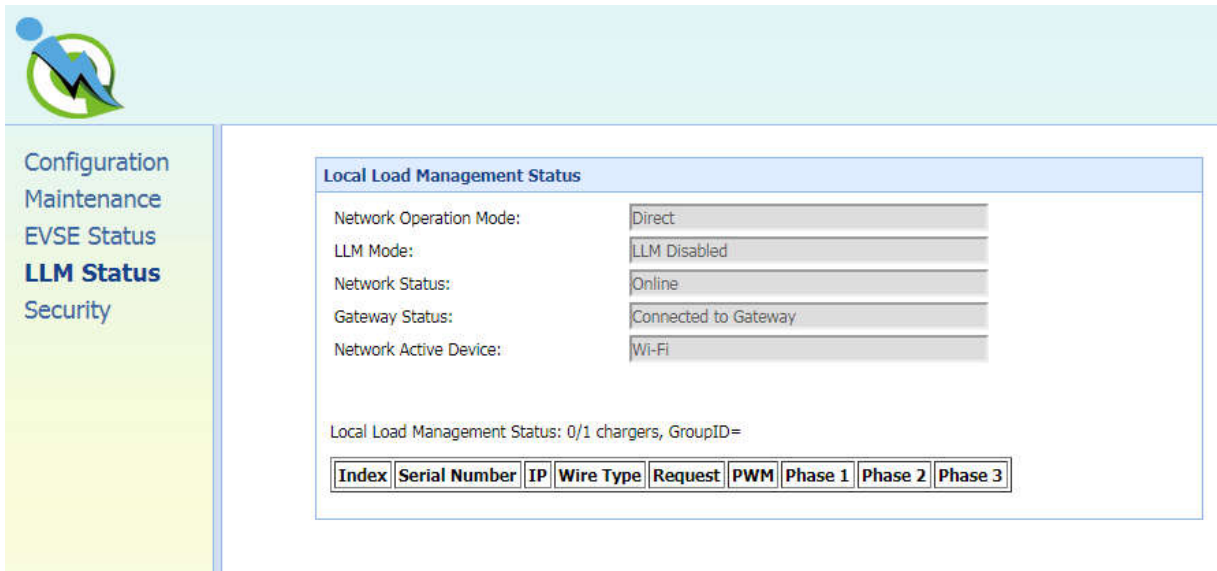

- The “**Local Load Management Status**” screen shows the Local Load Management (LLM) settings and current Master/Slave group member list.

3.8.6 Security menu

When you choose the **Security** menu, a sub menu will appear:

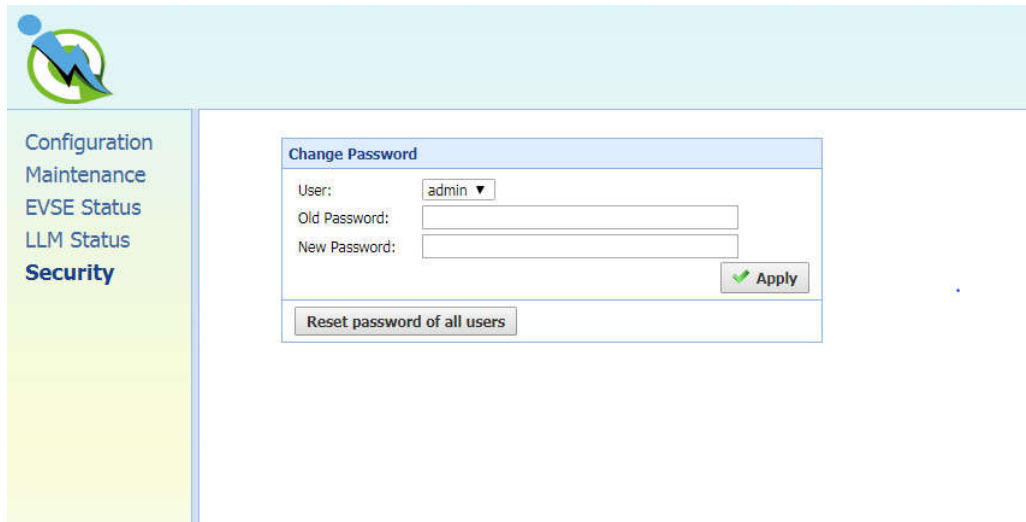

The screenshot shows a web interface with a light blue header and a yellow-green sidebar. The sidebar contains a navigation menu with the following items: Configuration, Maintenance, EVSE Status, LLM Status, and Security (highlighted in blue). The main content area displays a 'Change Password' form. The form has a title bar 'Change Password' and contains the following fields: 'User:' with a dropdown menu showing 'admin', 'Old Password:' with an empty text input, and 'New Password:' with an empty text input. To the right of the 'New Password:' field is a green 'Apply' button with a checkmark icon. Below the form is a button labeled 'Reset password of all users'.

- The “**Change Password**” screen can be used to change the password of users for this web portal.

3.9 Configuration (for SC3/IC3 only)

3.9.1 Factory settings

Clicking on the “**Configuration**” and then “**Factory Settings**” link will bring up the following screen:

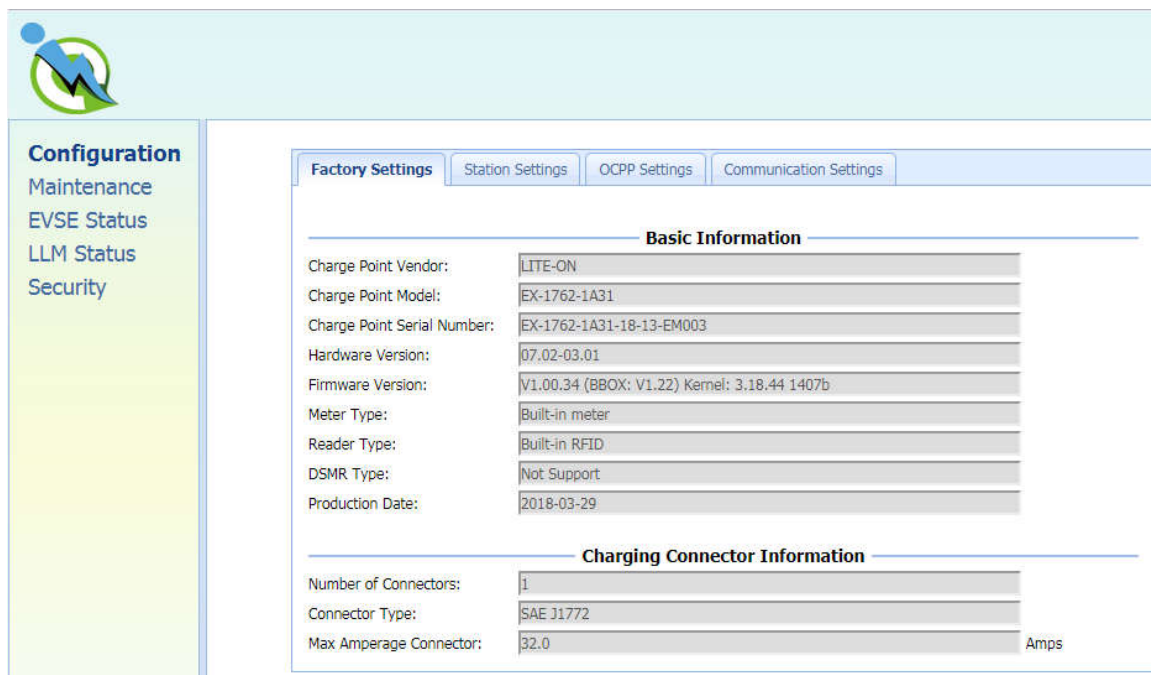

Basic Information	
Charge Point Vendor:	LITE-ON
Charge Point Model:	EX-1762-1A31
Charge Point Serial Number:	EX-1762-1A31-18-13-EM003
Hardware Version:	07.02-03.01
Firmware Version:	V1.00.34 (BBOX: V1.22) Kernel: 3.18.44 1407b
Meter Type:	Built-in meter
Reader Type:	Built-in RFID
DSMR Type:	Not Support
Production Date:	2018-03-29

Charging Connector Information	
Number of Connectors:	1
Connector Type:	SAE J1772
Max Amperage Connector:	32.0 Amps

Basic Information

Charge Point Vendor – The vendor’s name of the charge point.

Charge Point Model – The model’s name of the charge point.

Charge Point Serial Number – The unique serial number of the charge point.

Hardware Version – The hardware version of the charge point.

Firmware Version – The software version of the charge point.

Meter Type – The meter type of the charge point.

Reader Type – The reader type of the charge point. [Support only on IC3]

DSMR Type – The DSMR type of the charge point.

Production Date – The production date of the charge point.

Charging Connector Information

Number Of Connectors – Number of connectors of the charge point.

Connector Type* – Indicates type 1 or type 2 cable installed in the charge point.

Max Amperage Connector – The maximum charging current of the connector capability.

* A charge point may have multiple connectors installed. For SC3/IC3 series, there is only one connector on them.

3.9.2 Station settings

Clicking on the “**Configuration**” and then “**Station Settings**” link will bring up the following screen. Since the page is too long to display, we separate it to 2 screens.

On this page you can change the properties of the charge point. Click the “**Apply**” button at the right side of the property when the value is changed.

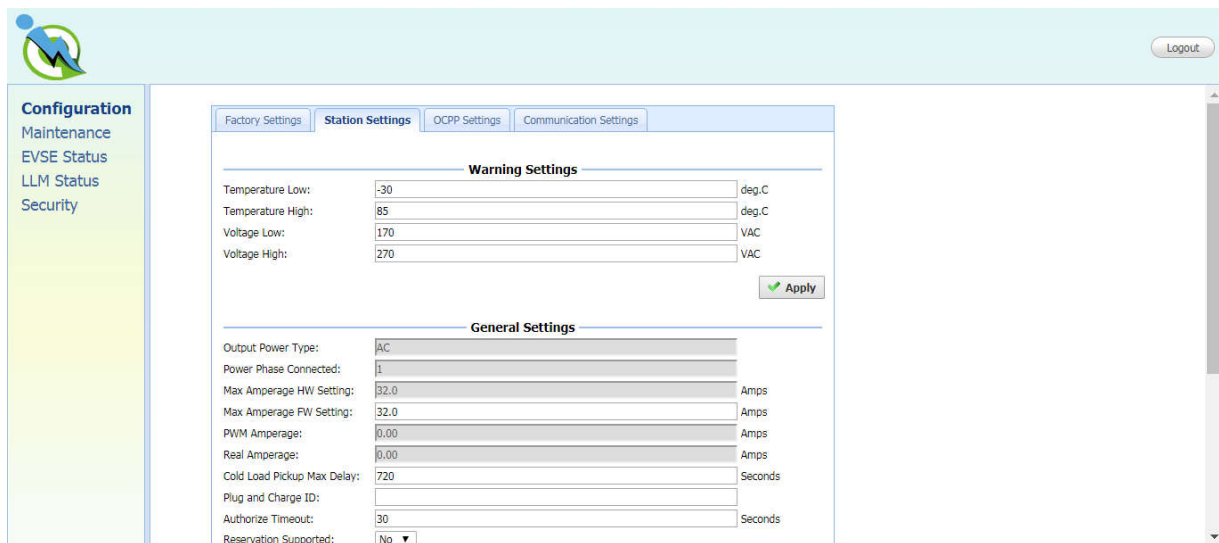

Warning Settings	
Temperature Low:	-30 deg.C
Temperature High:	85 deg.C
Voltage Low:	170 VAC
Voltage High:	270 VAC

General Settings	
Output Power Type:	AC
Power Phase Connected:	1
Max Amperage HW Setting:	32.0 Amps
Max Amperage FW Setting:	32.0 Amps
PWM Amperage:	0.00 Amps
Real Amperage:	0.00 Amps
Cold Load Pickup Max Delay:	720 Seconds
Plug and Charge ID:	
Authorize Timeout:	30 Seconds
Reservation Supported:	No

Warning Settings

Temperature Low – Value in Celsius at which the charge point will send a temperature low warning message.

Temperature High – Value in Celsius at which the charge point will send a temperature high warning message.

Voltage Low – Value at which the charge point will send an under voltage warning message.

Voltage High – Value at which the charge point will send an over voltage warning message.

General Settings	
Output Power Type:	AC
Power Phase Connected:	1
Max Amperage HW Setting:	32.0 Amps
Max Amperage FW Setting:	32.0 Amps
PWM Amperage:	0.00 Amps
Real Amperage:	0.00 Amps
Cold Load Pickup Max Delay:	720 Seconds
Plug and Charge ID:	
Reservation Supported:	Yes
Resume Charge After Reboot:	Off
RFID Reader:	On
Ventilation Required:	No
Skip HeartBeat Message:	Yes

Apply

General Settings

Output Power Type – AC or DC output power. For SC3/IC3 series, this value is always “AC”.

Power Phase Connected – Input power phase connected to the charge point to indicate single phase or three phases. For SC3/IC3 series, this value is always “1”.

Max Amperage HW Setting – The DIP switches (Hardware) settings to indicate the maximum charging current.

Max Amperage FW Setting – The software settings to indicate the maximum charging current.

PWM Amperage – The PWM setting for charging current when the charge point is online. This signal is to tell EV how much current is allowed to use.

Real Amperage – The real-time charging current detected by the charge point.

Cold Load Pickup Max Delay – Default cold load pickup delay is 120s ~ 720s. The max value could be changeable by this property.

Plug and Charge ID – If the value is present, the charge point needs to support plug and charge scenario by using the specific identifier. If absent, authorization for each session is required. This ID must be 8 or more characters.

Reservation Supported – If true, the charge point will support reservation related messages from Central System.

Resume Charge After Reboot – Indicate if the charge point resumes charging after power recycle. If true, the charge point will resume charging according to UL regulations. If false, the charge point will not resume charging.

RFID Reader – Indicate if RFID reader is available. [Support only on IC3]

Ventilation Required – Indicate if ventilation equipment is required. If set this option to yes, a ventilation fault will occur when the EV report for need ventilation equipment. Recommend setup value are shown below according to the place and ventilation equipment available or not.

Place	Ventilation Equipment Available	Ventilation Equipment Not Available
Indoor	No	Yes
Outdoor	No	No

Skip HeartBeat Message – Indicate if HeartBeat message is skipped if any other message is sent successfully during a heartbeat interval.

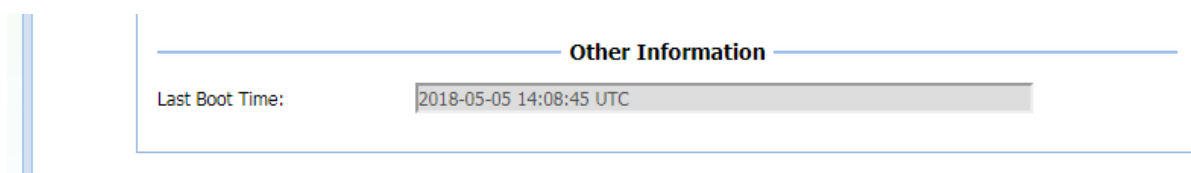

Other Information

Last Boot Time – Show last boot time.

3.9.3 OCPP settings

Clicking on the “**Configuration**” and then “**OCPP Settings**” link will bring up the following screen, since the page is too long to display, please using scrollbar to check remaining pages.

The screenshot shows the OCPP Settings configuration page. The page is divided into two main sections: Remote Control Settings and Service Settings. The Remote Control Settings section includes a dropdown menu for Remote Control Type* set to OCPP and an Apply button. The Service Settings section includes various input fields for Charge Point ID, Protocol Name, Central System URL, Basic Auth ID, Basic Auth Password, FTP Server Username, FTP Server Password, Message Transport Layer (set to WS), and several intervals and retries (Boot Notification, PDU Timeout, Download Firmware, Upload Diagnostic) with units in seconds. Each interval field has an Apply button on the right.

On this page you can change the properties just for the charge point. Click the “**Apply**” button at the right side of the property when the value is changed.

Remote Control Settings

Remote Control Type: The remote control mode accept by IC3. Options are

APP: IC3 can be remote controlled by mobile APP.

OCPP: IC3 can be remote controlled by OCPP 1.6 protocol.

Service Settings

Charge Point ID – The identity of the charge point as known in the OCPP Central System.

Protocol Name – The name and version of OCPP is running in the charge point.

Central System URL – The URL of the OCPP v1.6 Central System service.

Basic Auth ID – The ID for BASIC authentication in HTTPS (SSL/TLS) connections.

Basic Auth Password – The password for BASIC authentication in HTTPS (SSL/TLS) connections.

FTP Server Username – The username of the FTP Server for OCPP to download firmware files and upload diagnostic file.

FTP Server Password – The password of the FTP Server for OCPP to download firmware files and upload diagnostic file.

Message Transport Layer – Select the transport layer of the OCPP service that will be used. For Intelligent Charger-32A, the available option is **WS and WSS**.

WS: Connection from charge point to OCPP Server uses WebSocket protocol.

WSS: Connection from charge point to OCPP Server uses Secure WebSocket protocol.

Boot Notification Interval – Interval of re-sending BootNotification.req if not accepted by Central System.

Boot Notification Retries – Number of times to retry sending BootNotification.req.

“-1” means unlimited

“0” means don’t retry.

PDU Timeout – Interval until the charge point stop waiting for a PDU response.

Download Firmware Interval – Interval of downloading firmware from Central System.

Download Firmware Retries – Number of times to retry downloading firmware.

Upload Diagnostics Interval – Interval of uploading diagnostic file to Central System.

Upload Diagnostics Retries – Number of times to retry uploading diagnostic file.

OCPP1.6 Settings	
AllowOfflineTxForUnknownId:	Yes ▼
AuthorizationCacheEnabled:	Yes ▼
AuthorizeRemoteTxRequests:	No ▼
BlinkRepeat:	90 Times
ClockAlignedDataInterval:	900 Seconds
ConnectionTimeOut:	120 Seconds
GetConfigurationMaxKeys:	100
HeartBeatInterval:	43200 Seconds
LightIntensity:	100 %
LocalAuthorizeOffline:	Yes ▼
LocalPreAuthorize:	Yes ▼
MaxEnergyOnInvalidId:	7360 Wh
MeterValuesAlignedData:	Energy.Active.Import.Register
MeterValuesAlignedDataMaxLength:	10
MeterValuesSampledData:	Energy.Active.Import.Register
MeterValuesSampledDataMaxLength:	10
MeterValueSampleInterval:	900 Seconds
MinimumStatusDuration:	10 Seconds
NumberOfConnectors:	1
ResetRetries:	0 Times
ConnectorPhaseRotation:	NotApplicable ▼

OCPP1.6 Settings

These settings are defined and request for support in OCPP 1.6 specification.

AllowOfflineTxForUnknownId – If set to yes, an unknown ID (not in Authorization and Cache List) will be accepted and start the charging session when charge point is not connected to central system.

AuthorizationCacheEnabled – Charge point supports an Authorization Cache or not.

AuthorizeRemoteTxRequests – Whether a remote request to start a transaction in the form of a RemoteStartTransaction.req message should be authorized beforehand like a local action to start a transaction.

BlinkRepeat – Number of times to blink the charge point lighting when signaling. This value is not changeable for IC3/SC3.

ClockAlignedDataInterval – Size (in seconds) of the clock-aligned data interval. This is the size (in seconds) of the set of evenly spaced aggregation intervals per day, starting at 00:00:00 (midnight).

ConnectionTimeOut – Interval until incipient charging session is automatically canceled due to failure of EV user to insert the charging cable connector(s) into the appropriate connector(s).

GetConfigurationMaxKeys – Maximum number of requested configuration keys in a GetConfiguration.req PDU.

HeartBeatInterval – Defines the heartbeat interval.

LightIntensity – Percentage of maximum intensity at which to illuminate the charge point lighting. This value is not changeable for IC3/SC3.

LocalAuthorizeOffline – Whether the charge point, when offline, will start a transaction for locally-authorized identifiers.

LocalPreAuthorize – Whether the charge point, when online, will start a transaction for locally authorized identifiers without waiting for or requesting an Authorize.conf from Central System.

MaxEnergyOnInvalidId – Maximum energy in Watt-hour (Wh) delivered when an identifier is invalidated by Central System after start of a transaction.

MeterValuesAlignedData – Clock-aligned measurand(s) to be included in a MeterValues.req PDU, every ClockAlignedDataInterval seconds. Supported values are Current.Import, Energy.Active.Import.Register, and Temperature, Voltage or any combination of these 4 values.

MeterValuesAlignedDataMaxLength – Maximum number of items in a MeterValuesAlignedData configuration key.

MeterValuesSampledData – Sampled measurands to be included in a MeterValues.req PDU, every MeterValueSampleInterval seconds. Supported values are Current.Import, Energy.Active.Import.Register, and Temperature, Voltage or any combination of these 4 values.

MeterValuesSampledDataMaxLength – Maximum number of items in a MeterValuesSampledData configuration key.

MeterValueSampleInterval – Interval between sampling of metering (or other) data, intended to be transmitted by "MeterValues" PDUs

MinimumStatusDuration – The minimum duration that a charge point or connector status is stable before a StatusNotification.req PDU is sent to Central System.

NumberOfConnectors – The number of physical charging connectors of this charge point.

ResetRetries – Number of times to retry an unsuccessful reset of the charge point.

ConnectorPhaseRotation – The phase rotation per connector in respect to the connector's energy meter. This is not supported by IC3/SC3 since it is single phase power input and the value will always be 'NotApplicable'.

ConnectorPhaseRotationMaxLength:	1	
StopTransactionOnEVSideDisconnect:	Yes ▾	
StopTransactionOnInvalidId:	Yes ▾	
StopTxnAlignedData:	Current.Import,Energy.Active.Import.Register,Temperature,Voltz ▾	
StopTxnAlignedDataMaxLength:	10	
StopTxnSampledData:	Current.Import,Energy.Active.Import.Register,Temperature,Voltz ▾	
StopTxnSampledDataMaxLength:	10	
SupportedFeatureProfiles:	Core,Firmware Management,Local Auth List Management,Reservati	
SupportedFeatureProfilesMaxLength:	6	
TransactionMessageAttempts:	10	Times
TransactionMessageRetryInterval:	10	Seconds
UnlockConnectorOnEVSideDisconnect:	Yes ▾	
WebSocketPingInterval:	900	Seconds
LocalAuthListEnabled:	Yes ▾	
LocalAuthListMaxLength:	100	
SendLocalListMaxLength:	100	
ReserveConnectorZeroSupported:	Yes ▾	
ChargeProfileMaxStackLevel:	99	
ChargingScheduleAllowedChargingRateUnit:	Current	
ChargingScheduleMaxPeriods:	32	
ConnectorSwitch3to1PhaseSupported:	No ▾	
MaxChargingProfilesInstalled:	10	

Apply

ConnectorPhaseRotationMaxLength – Maximum number of items in a ConnectorPhaseRotation configuration key.

StopTransactionOnEVSideDisconnect – When set to true, the charge point SHALL administratively stop the transaction when the cable is unplugged from the EV.

StopTransactionOnInvalidId – Whether the charge point will stop an ongoing transaction when it receives a non-accepted authorization status in a StartTransaction.conf for this transaction.

StopTxnAlignedData – Clock-aligned periodic measurand(s) to be included in the TransactionData element of StopTransaction.req MeterValues.req PDU for every ClockAlignedDataInterval of the charging session. Supported value are Current.Import, Energy.Active.Import.Register, and Temperature, Voltage or any combination of these 4 value.

StopTxnAlignedDataMaxLength – Maximum number of items in a StopTxnAlignedData configuration key.

StopTxnSampledData – Sampled measurands to be included in the TransactionData element of StopTransaction.req PDU, every MeterValueSampleInterval seconds from the start of the charging session. Supported value are Current.Import, Energy.Active.Import.Register, and Temperature, Voltage or any combination of these 4 value.

StopTxnSampledDataMaxLength – Maximum number of items in a StopTxnSampledData configuration key.

SupportedFeatureProfiles – A list of supported Feature Profiles. Possible profile identifiers: Core, FirmwareManagement, LocalAuthListManagement, Reservation, SmartCharging and RemoteTrigger.

SupportedFeatureProfilesMaxLength – Maximum number of items in a SupportedFeatureProfiles configuration key.

TransactionMessageAttempts – How often the charge point should try to submit a transaction-related message when Central System fails to process it.

TransactionMessageRetryInterval – How long the charge point should wait before resubmitting a transaction-related message that Central System failed to process.

UnlockConnectorOnEVSideDisconnect – When set to true, the charge point SHALL unlock the cable on charge point side when the cable is unplugged at the EV. This is not supported by IC3/SC3 since it is plug type and no connector locker.

WebSocket Ping Interval – Define the ping pong interval for WebSocket protocol.

LocalAuthListEnabled – Whether the Local Authorization List is enabled.

LocalAuthListMaxLength – Maximum number of identifications that can be stored in the Local Authorization List.

SendLocalListMaxLength – Maximum number of identifications that can be send in a single SendLocalList.req.

ReserveConnectorZeroSupported – If this configuration key is present and set to true: The charge point support reservations on connector 0.

ChargeProfileMaxStackLevel – Max Stack Level of a Charging Profile. The number defined also indicates the max allowed number of installed charging schedules per Charging Profile purposes.

ChargingScheduleAllowedChargingRateUnit – A list of supported quantities for use in a Charging Schedule. This value will always be 'Current' for IC3/SC3.

ChargingScheduleMaxPeriods – Maximum number of periods that may be defined per Charging Schedule.

ConnectorSwitch3to1PhaseSupported – If defined and true, this charge point supports switching from 3 to 1 phase during a charging session. This is not supported by IC3/SC3 since it is single phase power input

MaxChargingProfilesInstalled – Maximum number of charging profiles installed at a time.

3.9.4 Communication settings

Clicking on the “**Configuration**” and then “**Communication Settings**” link will bring up the following screen. Since the page is too long to display, we separate it to couple screens.

On this page you can set up the network connection. To finish, click the “**Apply**” button.

The screenshot shows the 'Communication Settings' configuration page. It includes a sidebar with 'Configuration', 'Maintenance', 'EVSE Status', and 'LLM Status'. The main content area has tabs for 'Factory Settings', 'Station Settings', 'OCPP Settings', and 'Communication Settings'. The 'Communication Settings' tab is active, showing fields for 'Network Mode*' (Direct), 'Gateway LAN IP' (192.168.199.1), 'Gateway LAN Port (SOAP)' (8080), 'Max Group Size' (12), 'Gateway Serial Number', 'Group Use External Gateway*' (No), 'Hide AP SSID' (Off), 'Connectivity' (Wi-Fi), and 'LED Brightness' (20%). Below these is a section for 'Active Device Status' with fields for 'Active Device' (Wi-Fi), 'Active IP Address' (192.168.0.18), 'Active Netmask' (255.255.255.0), 'Active Gateway' (192.168.0.1), 'Active Primary DNS', and 'Active Secondary DNS'. At the bottom, there is a section for 'Wi-Fi Settings'.

Network Mode – Specifies if enable the Local Proxy function. Available options are **Gateway**, **Client** and **Direct**.

Direct: Use charge point as a single device.

Gateway: Use charge point as a gateway charge point. Gateway connected to OCPP 1.6 Server via cellular or Wi-Fi and connected to other charge points (called Client) via Wi-Fi and forms a local charge points group. This group is also a LAN (Local Area Network).

Client: Use charge point as a client charge point. Client connected to Gateway via Wi-Fi. Client connected to OCPP1.6 Server through gateway charge point (via cellular or Wi-Fi) and Gateway will dispatch incoming remote command to proper client charge points (or Gateway itself).

NOTE

Network mode are used to change how a group IC3/SC3 connecting to the internet. If a charge point's network mode is **Client**, then there must be a **Gateway** in this group and all client charge points are connected to the internet via Gateway. These chargers form a Gateway/Client group. In this group there is exact one **Gateway** and all other charge points are **Client**.

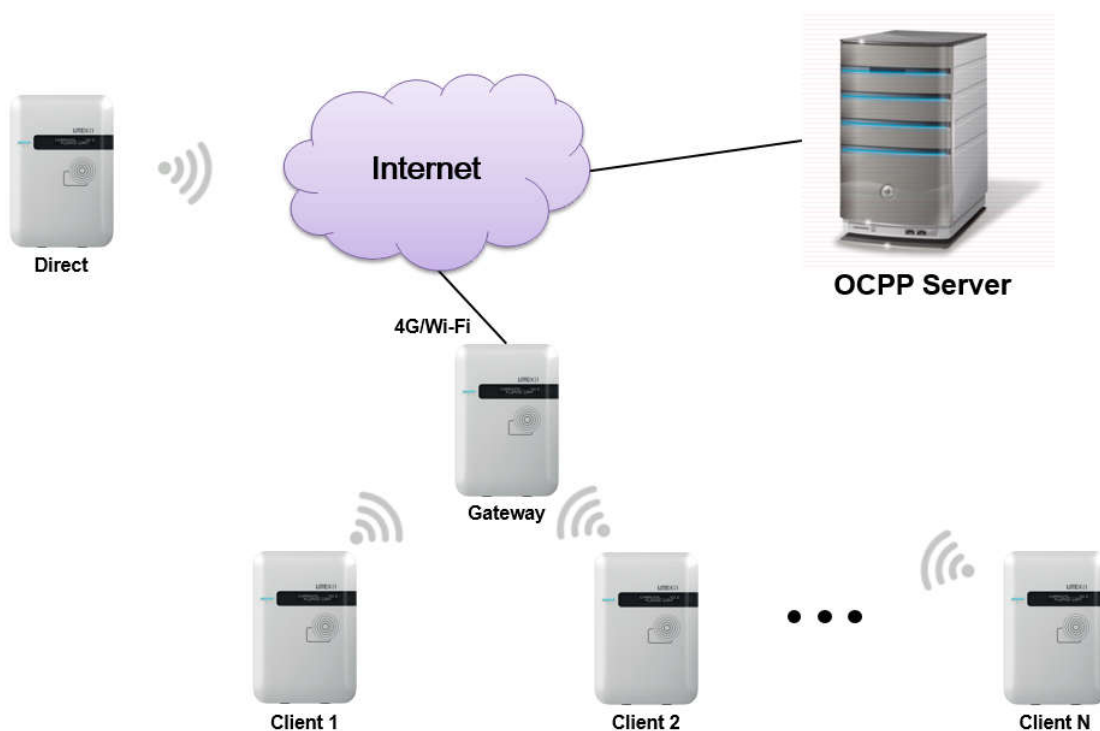

Gateway LAN IP – The IP of master in LAN. This value cannot be modified by users.

Gateway LAN Port (SOAP) – The listen port for OCPP SOAP client server. This value cannot be modified by users.

Max Group Size – The maximum number of charge points allowed in a group/LAN. This value cannot be modified by users.

Gateway Serial Number – The serial number of the charge point which acts as a Gateway.

Group Use External Gateway – Gateway/Client mode use external gateway as a local network group or not (use Gateway IC3).

NOTE

A Gateway charge point can choose using Wi-Fi or Cellular to connect to the internet by change 'Group Use External Gateway' setting. If set to **No**, a **Gateway** will use Cellular, or it will use Wi-Fi. When changed this setting, the 'Connectivity' option will automatically change as well.

All charge point in this Gateway/Client group must have the same 'Group Use External Gateway' setting, i.e. all charge points must set this option to Yes (including **Gateway** and **Client**) when we want to use an external Wi-Fi AP to connect to internet. In this case, all charge points must also use the same Wi-Fi settings (SSID, password) for the external Wi-Fi AP.

Hide AP SSID – Options for hiding SSID of this charge point or not. For IC3/SC3 this option is always off.

Connectivity – Specifies whether the charge point should always be connected to Internet using **None**, **Auto**, **Wi-Fi**, or **Cellular**. Default value is Auto. [Cellular: IC3 support only] When Network Mode is Direct, all option are available. If it is not, then Connectivity will be set with the following rule:

Network Mode	Group Use External Gateway = Yes	Group Use External Gateway = No
Gateway	Wi-Fi	Cellular
Client	Wi-Fi Wi-Fi setting will be disabled and Client will setup Wi-Fi to connect to Gateway indicated by 'Gateway Serial Number'	Wi-Fi

LED brightness – The user can modify the LED brightness according to the user's environment and preferences. There are five settings: 20%, 40%, 60%, 80%, 100%. (Default setting is 20%)

Active Device Status

Active Device – Current active network device. Possible value are None, Wi-Fi or Cellular

Active IP Address – Current active IP address. There will be value here only if connected to a network.

Active Netmask – Current active netmask address. There will be value here only if connected to a network.

Active Gateway – Current active gateway IP address. There will be value here only if connected to a network and network provide this data.

Active Primary DNS – Current active primary DNS IP address. There will be value here only if connected to a network and network provide this data.

Active Secondary DNS – Current active secondary DNS IP address. There will be value here only if connected to a network and network provide this data.

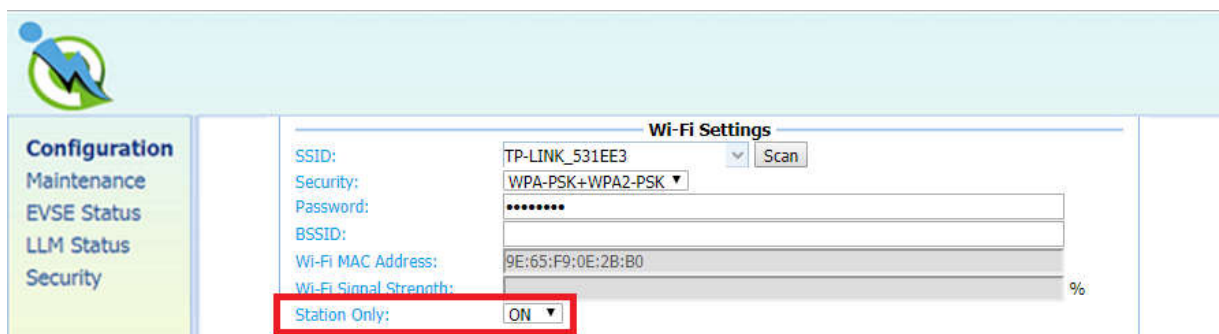

Wi-Fi Settings

SSID – The SSID name of Wi-Fi Access Point. Press Scan button to scan and receive current detectable Wi-Fi signal.

Security – The encryption of Wi-Fi Access Point. Options are None, WEP, WPA-PSK, WPA2-PSK, WPA-PSK+WPA2-PSK and Auto.

Password – The password of Wi-Fi Access Point.

BSSID – The MAC Address of Wi-Fi Access Point. If your Access Point is hidden SSID, please enter this address.

Wi-Fi MAC Address – Display Wi-Fi device hardware MAC address.

Wi-Fi Signal Strength – Display the wireless signal strength of Wi-Fi in percentage (%).

Station Only – If "Station Only" is ON, the charger will stay in station mode always. If "Station Only" is OFF, it will go into AP mode after 5 times retrying to connect the external Wi-Fi AP.

Note:

The **Station Only** option only work if remote control type is OCPP. If the remote control type is APP → it keeps original behavior (retry 5 times and go to AP mode) no matter what **Station Only** option selected.

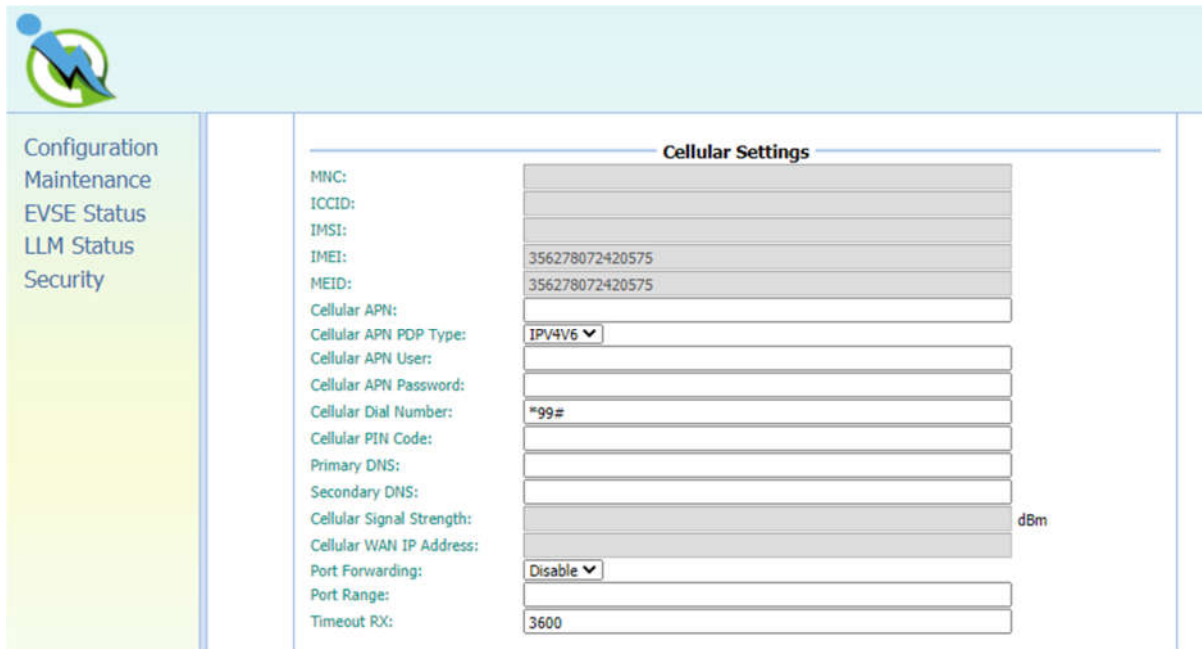

Cellular Settings	
MNC:	
ICCID:	
IMSI:	
IMEI:	356278072420575
MEID:	356278072420575
Cellular APN:	
Cellular APN PDP Type:	IPv4V6
Cellular APN User:	
Cellular APN Password:	
Cellular Dial Number:	*99#
Cellular PIN Code:	
Primary DNS:	
Secondary DNS:	
Cellular Signal Strength:	
Cellular WAN IP Address:	
Port Forwarding:	Disable
Port Range:	
Timeout RX:	3600

Cellular Settings [Support only on IC3]

MNC – The Mobile Network Code of cellular service provider. There will be no data here if no 3G/LTE signal.

ICCID – The ICCID of the modem's SIM card. There will be no data here if no SIM card inserted.

IMSI – The IMSI of the modem's SIM card. There will be no data here if no SIM card inserted.

IMEI – The IMEI (International Mobile Equipment Identity) of the modem.

MEID – The MEID (Mobile Equipment Identifier) of the modem.

Cellular APN – This is the gateway for all cellular traffic. Contact your cellular operator for information about this. For AT&T and Verizon LTE service, just leave it blank since the apn name is built-in in the modem.

Cellular APN PDP Type – An option to select the PDP type for APN configuration. The default of Cellular APN PDP Type is IPV4V6.

APN Username – This is the user name your ISP has assigned to you (**optional**).

APN Password – Password to log into the ISP network (**optional**).

Dial Number – Phone number to dial for cellular network.

PIN Code – PIN code for the modem’s SIM card (**optional**). 4 digit number.

Primary DNS – The primary Domain Name Server (**optional**).

Secondary DNS – The secondary Domain Name Server (**optional**).

Cellular Signal Strength – The strength of cellular signal in dBm.

Cellular WAN IP Address – IP address of Cellular network.

Port Forwarding – To redirect a communication request from one address and port number combination to another while the packets are traversing a network gateway.

Port Range – A port number is a 16-bit unsigned integer ranging from 0 to 65535. Port range defines a range which can be used. The format for numeric port range is minimum-value:maximum-value.

Timeout RX – Timeout limitation of signal received by modem.

The screenshot shows the 'Local Load Management (LLM) Settings' interface. It includes the following fields and values:

Setting	Value	Unit
Local Load Management**:	Disable	
Charging Policy**:	Uniform Distribution	
Group ID:		
Group Size:	1	
Max Amperage Grid Connection:	100	Amps
Fallback Current:	6.0	Amps

An 'Apply' button with a green checkmark is located at the bottom right of the settings panel.

Local Load Management (LLM) Settings [Support only on IC3]

Local load management is the process of balancing the supply of electricity on the network with the electrical load by adjusting or controlling the load of each charge point in a local group which is based on Gateway/Client architecture. The Gateway IC3 must be manually set to the maximum current limitations so that it will dynamically adjust output current in each Client IC3 by charging policy.

When LLM function is on, all charge points will request for charging to Gateway, and Gateway will calculate the proper current limit and reply to each Client. Each charge point will only allow charging when received a current limit from Gateway. If disconnection occurred between a Client and Gateway then the Client will use fallback value as the limitation.

Local Load Management – Enable or disable Local Load Management function. This function can only be enabled in a **Gateway** or **Client** charge point.

HINT: If user changes “Network Mode” setting, then related settings will also change automatically such as “Connectivity”, “Local Load Management”. The default value is as follow:

	Direct	Gateway	Client
Gateway LAN IP	Not used	Default value, not changeable	Not used
Gateway LAN Port	Not used	Default value, not changeable	Not used
Max Group Number	Not used	Default value, not changeable	Not used
Group Use External Gateway	Not used	Yes or No	Yes or No
Gateway Serial Number	Not used	Not used	Used
Connectivity	Auto	Wi-Fi or Cellular	Wi-Fi, not changeable
Local Load Management	Disable, not changeable	Enable	Enable

Charging Policy – The charging policy for LLM Gateway to decide the charging current for each charge point. Valid options are:

- 1) UD (default): Uniform Distribution. The maximum amperage is divided by total numbers of charging EV, i.e. each EV will use the same charging current.
- 2) FIFS: First In First Serve.

Group ID – An identity of the LLM group. A slave with different group identity will be rejected when attempting to connect to Gateway.

Group Size – The total number of charge points in the LLM group. This value is only used in Gateway.

Max Amperage Grid Connection – Total ampere of each phase allowed loading for the group of charge points at the same time. This value is only used in Gateway.

Fallback Current – The fallback current when Client is not able to communicate with Gateway. Gateway will overwrite fallback current in Client with its own value when Client connected to Gateway.

Note

Any option followed by a star mark (*) means the setting need to reboot to take effect. When these value changed and applied the web portal will display a reminder message box for rebooting the charge point.

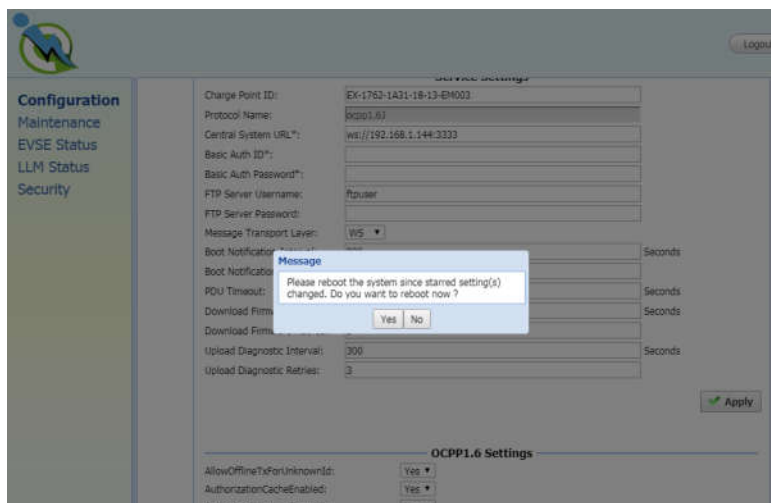

3.10 Maintenance (for SC3/IC3 only)

This page includes some maintenance functions.

The screenshot shows the Maintenance page interface. On the left, a sidebar lists 'Configuration', 'Maintenance' (selected), 'EVSE Status', 'LLM Status', and 'Security'. The main content area contains several functional sections: 'Command' with 'Reboot' and 'Reset to MFG default' buttons; 'Charging Profile Data' with 'Show All Charging Profile Data' and 'Clear All Charging Profile Data' buttons; 'Local Authorization' with 'Show Local Authorization List' and 'Clear Local Authorization List' buttons, followed by a file upload section with 'Choose File', 'No file chosen', and 'Upload List' buttons; another 'Show Authorization Cache List' and 'Clear Authorization Cache List' buttons, followed by another file upload section with 'Choose File', 'No file chosen', and 'Upload Cache' buttons; and finally 'Firmware Upgrade' with 'Choose File', 'No file chosen', and 'Upload' buttons.

3.10.1 Reboot

Command

Reboot: To restart the charge point.

Reset to MFG default: To reset to the factory default settings.

Charging Profile Data

HINT: Charging Profile is defined in OCPP 1.6 specification for smart charging. A charging profile consists of a charging schedule, which is basically a list of time intervals with their maximum charge power or current, and some values to specify the time period and recurrence of the schedule.

Show All Charging Profile Data: To show the list of Charging Profiles. There will be a display window. The data display here is a RAW data, usually for diagnostic use.

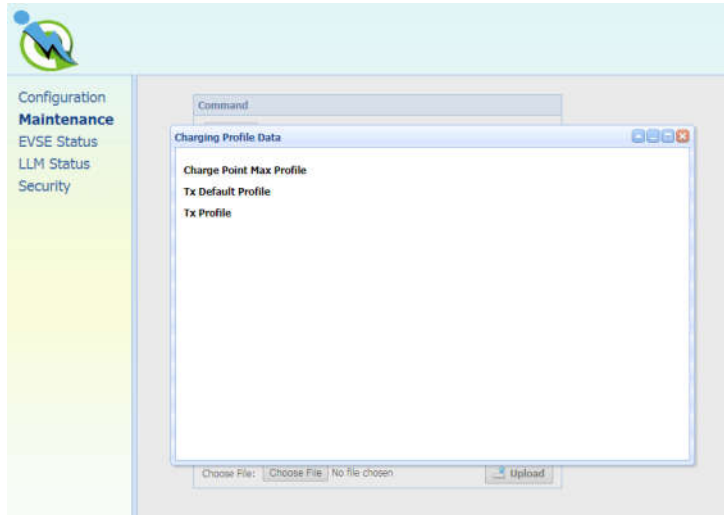

Clear All Charging Profile Data: To clear all Charging Profile data.

Local Authorization

HINT: Local authorization is defined in OCPP 1.6 specification. There are two local list: Local Authorization List and Authorization Cache List. The Local Authorization List is a list of identifiers that can be synchronized with the Central System. An Authorization Cache autonomously maintains a record of previously presented identifiers that have been successfully authorized by the Central System.

Show Local Authorization List: To show the list of Local Authorization. Each line of the list shown below indicates a RFID card info. The syntax is

CARD_IDTAG|EXPIRY_DATE|PARENT_CARD_IDTAG|CARD_STATUS

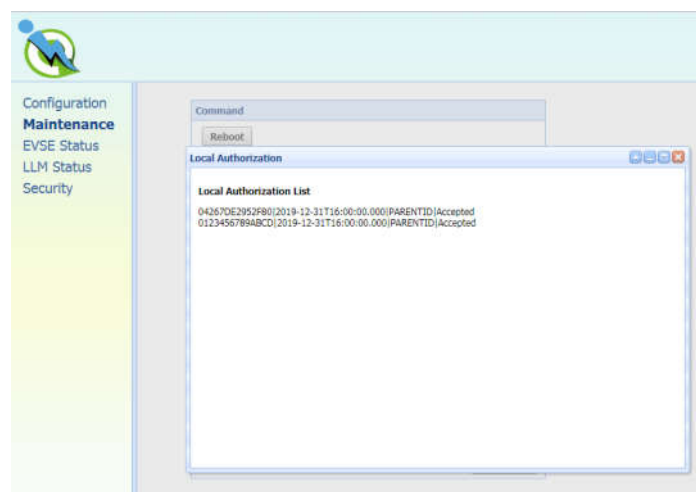

Clear Local Authorization List: To clear the list of Local Authorization.

Upload List: Upload a csv file which including card info to Local Authorization List.

A csv file is a plain text file which each line represent a RFID card info. The format of a card info is as follow:

CARD_IDTAG,EXPIRY_DATE,PARENT_CARD_IDTAG,CARD_STATUS

CARD_IDTAG: 8 ~ 20 character RFID card ID tag combined with alphabet or numbers.

EXPIRY_DATE: The date at which idTag should be removed from the Authorization Cache. Format is *YYYY-MM-DDThh:mm:ss.ttt* which indicates a date in AD.

Example: 2019-12-31T16:00:00.000

PARENT_CARD_IDTAG: the parent-identifier of the card. The format is same as CARD_IDTAG.

CARD_STATUS: This contains whether the idTag has been accepted or not by the Central System. Valid options are **Accepted, Blocked, Expired** or **Invalid**. This string is case sensitive.

Sample data: **0123456789ABCD,2019-12-31T16:00:00.000,PARENTID,Accepted**

Show Authorization Cache List: To show the list of Authorization Cache. Each line of the list shown below indicates a cached RFID card info. The syntax is

CARD_IDTAG|EXPIRY_DATE|PARENT_CARD_IDTAG|CARD_STATUS|CACHED_DATE

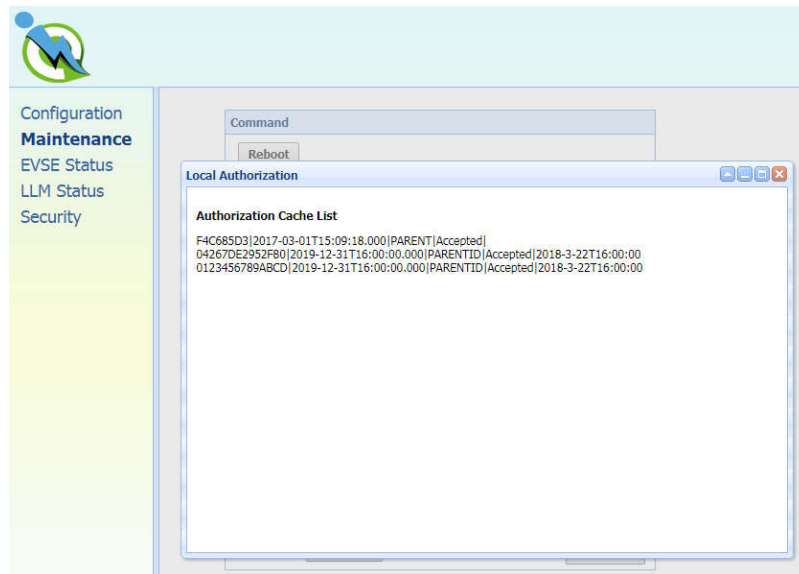

Clear Authorization Cache List: To clear the list of Authorization Cache.

Upload Cache: Upload a csv file which including cached card info to Authorization Cache List.

A csv file is a plain text file which each line represent a cached RFID card info. The format of a cached card info is as follow:

CARD_IDTAG,EXPIRY_DATE,PARENT_CARD_IDTAG,CARD_STATUS,CACHED_DATE

CARD_IDTAG: 8 ~ 20 character RFID card ID tag combined with alphabet or numbers.

EXPIRY_DATE: The date at which idTag should be removed from the Authorization Cache. Format is *YYYY-MM-DDThh:mm:ss.ttt* which indicates a date in AD.

Example: 2019-12-31T16:00:00.000

PARENT_CARD_IDTAG: the parent-identifier of the card. The format is same as CARD_IDTAG.

CARD_STATUS: This contains whether the idTag has been accepted or not by the Central System. Valid options are **Accepted**, **Blocked**, **Expired** or **Invalid**. This string is case sensitive.

CACHED_DATE: The date that the idTag be cached. Format is identical to EXPIRY_DATE. Sample

data: **0123456789ABCD,2019-12-31T16:00:00.000,PARENTID,Accepted,2018-3-22T16:00:00**

3.10.2 Firmware upgrade

To upgrade the firmware of the charge point, you need to download the upgrade image file to your local hard disk, and then click the “**Choose File**” button to locate the firmware file on your computer. Once you have selected the new firmware file, click the “**Upload**” button to start the upgrade process. After a successful upgrade, the web portal will be log out and charge point will reboot.

Although the web portal does not forbid upload firmware to previous version, but since the design of firmware upgrade file is including all backward modifications, downgrading firmware may cause unpredicted problem and is not recommended.

3.11 EVSE Status

To check the specific information of EVSE, you can click the corresponding buttons:



3.12 LLM Status (for SC3/IC3 only)

3.12.1 LLM information

This page shows the Local Load Management information of the charge point. For more LLM description, please refer to section 3.9.4.

Network Operation Mode: Indicates the charge point is in Direct mode, a Gateway or a Client.

LLM Mode: Indicates Local Load Management function is enabled or disabled.

Network Status: Indicates if the charge point is online or not.

Gateway Status: Indicates if the charge point is connected to the Gateway if it's a Client. For Direct and Gateway, it always shows "Connected to Gateway".

Network Active Device: Indicates the Network connected via which device. It could be Offline, Wi-Fi or Cellular.

Local Load Management Status: Display connected charge points, total charge points, Group ID of the LLM group as well as a full table of detail information each charge point if this charge point is Gateway.

Configuration
Maintenance
EVSE Status
LLM Status
Security

Local Load Management Status

Network Operation Mode:	Direct
LLM Mode:	LLM Disabled
Network Status:	Online
Gateway Status:	Connected to Gateway
Network Active Device:	Wi-Fi

Local Load Management Status: 0/1 chargers, GroupID=

Index	Serial Number	IP	Wire Type	Request	PWM	Phase 1	Phase 2	Phase 3
-------	---------------	----	-----------	---------	-----	---------	---------	---------

3.12.2 Gateway/Client group table

If the charge point is Gateway, the following LLM Group Table is present.

Index: The order of the charge point. The index is first connected to Gateway first showed.

Serial Number: The serial number (Charge Point Identity) of each charge point.

IP: The private local IP address in LLM group of each charge point.

Wire Type: The power source wire type of each charge point.

Request: The requested current of each charge point

PWM: The PWM (charger allowed) current of each charge point

Phase 1, Phase 2, Phase 3: The real current loaded by the vehicles of each charge point.

For Intelligent Charger-32A only Phase 1 has current.

Index	Serial Number	IP	Wire Type	Request	PWM	Phase 1	Phase 2	Phase 3
1	04000023	192.168.199.62	L1 L2 L3	32.0	32.0	15.1	0.7	0.8
2(M)	04000080	10.81.19.91	L1 L2 L3	32.0	32.0	13.7	0.7	0.8
3	04000026	192.168.199.53	L3 L1 L2	0.0	0.0	0.0	0.0	0.0
4	04000046	192.168.199.50	L1 L2 L3	32.0	32.0	0.0	0.0	0.0
5	04000070	192.168.199.51	L3 L1 L2	32.0	32.0	0.0	0.0	0.0
6	04000092	192.168.199.57	L2 L1 L3	32.0	32.0	0.0	0.0	0.0
7	04000071	192.168.199.49	L2 L1 L3	0.0	0.0	0.0	0.0	0.0
8	04000090	192.168.199.48	L1 L2 L3	32.0	32.0	0.0	0.0	0.0
9	04000032	192.168.199.47	L3 L1 L2	0.0	0.0	0.0	0.0	0.0
10	04000050	192.168.199.52	L1 L2 L3	32.0	32.0	14.3	0.1	0.1
11	04000064	192.168.199.46	L2 L1 L3	32.0	32.0	0.5	15.7	0.3
12	04000024	192.168.199.58	L2 L1 L3	0.0	0.0	0.0	0.0	0.0
13	04000027	192.168.199.56	L2 L1 L3	32.0	32.0	0.5	15.0	0.5
14	04000020	192.168.199.54	L3 L1 L2	32.0	32.0	5.0	0.6	0.6
15	04000054	192.168.199.61	L3 L1 L2	32.0	32.0	14.4	0.7	0.7
16	04000036	192.168.199.63	L1 L2 L3	32.0	32.0	0.5	0.5	0.5
17	04000082	192.168.199.59	L3 L1 L2	0.0	0.0	0.0	0.0	0.0
18	04000049	192.168.199.64	L2 L1 L3	0.0	0.0	0.0	0.0	0.0
19	04000079	192.168.199.55	L1 L2 L3	32.0	32.0	0.0	0.0	0.0
20	04000076	192.168.199.60	L1 L2 L3	32.0	32.0	0.8	0.9	0.9

Total: Request: 448.0 A, PWM: 448.0 A, Phase1: 64.8 A, Phase2: 34.9 A, Phase3: 5.2 A

3.12.3 Operation mode

There are two different operation modes, **Distribution mode** and **Priority mode**. Each time when a new coming car is plugged-in and start charging. The LLM gateway will re-calculate the proper ampere for each charging station.

Base on the different mode, the algorithm is different.

➤ **Distribution mode (Uniform Distribution)**

The available current is divided equally amongst all available charging stations.

■ **Example 1**

In this example, there are three (32A) charging stations in the LLM group. Setting up each charging stations according to the following settings:

Setting	Gateway	Client
Local Load Management	Enable	Enable
Charging Policy	Uniform Distribution	Not used
Group ID	LLM-Group-1	LLM-Group-1 (Same as Gateway)
Group Size	3	Not used
Max Amperage Grid Connection	60	Not used
Fallback Current	10	10 (Same as Gateway)

With one connected vehicle, the charging current is 32A.

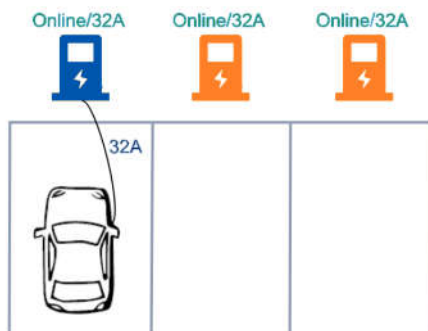

With two connected vehicles, the charging currents are evenly reduced to 30A.

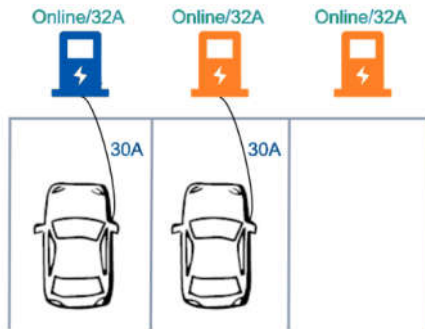

With three connected vehicles, the charging currents are further reduced to 20A.

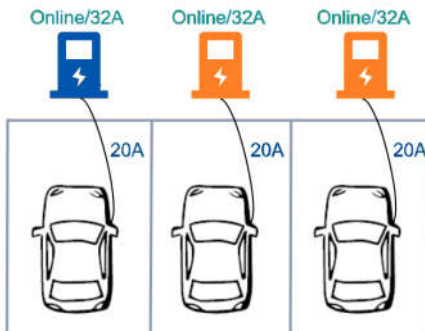

■ Example 2

In this example, there are two (32A) charging stations and one (16A) charging station in the LLM group. Setting up each charging stations according to the following settings:

Setting	Gateway	Client
Local Load Management	Enable	Enable
Charging Policy	Uniform Distribution	Not used
Group ID	LLM-Group-1	LLM-Group-1 (Same as Gateway)
Group Size	3	Not used
Max Amperage Grid Connection	60	Not used

Fallback Current	10	10 (Same as Gateway)
-------------------------	-----------	---------------------------------------

With one connected vehicle, the charging current is 32A.

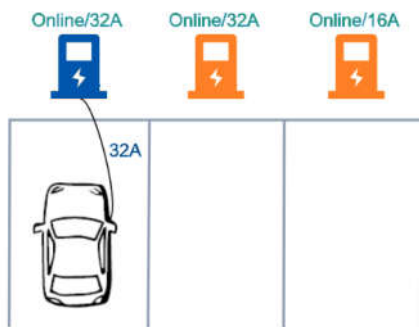

With two connected vehicles, the charging currents are evenly reduced to 30A.

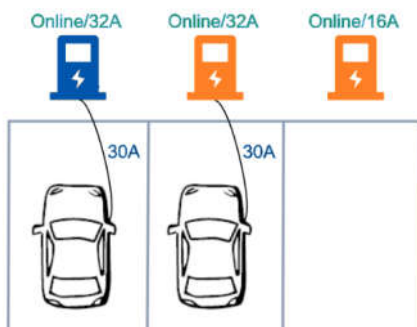

With three connected vehicles, the charging currents are further reduced to 24A for 32A charging stations and the charging current is 12A for 16A charging station.

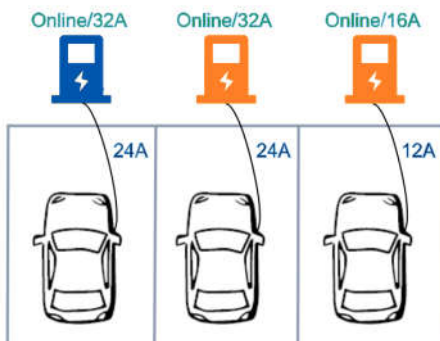

■ **Example 3**

In this example, there are five (32A) charging stations in the LLM group and two of the charging stations are offline. Setting up each charging stations according to the following settings:

Setting	Gateway	Client
Local Load Management	Enable	Enable
Charging Policy	Uniform Distribution	Not used
Group ID	LLM-Group-1	LLM-Group-1 (Same as Gateway)
Group Size	5	Not used
Max Amperage Grid Connection	80	Not used
Fallback Current	10	10 (Same as Gateway)

With one connected vehicle, the charging current is 32A. (Reserve 20A for offline charging stations)



With two connected vehicles, the charging currents are evenly reduced to 30A. (Reserve 20A for offline charging stations)

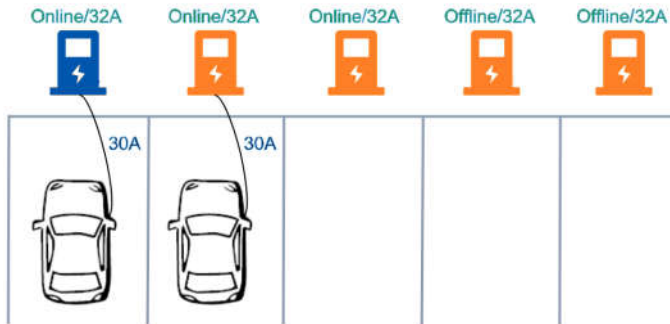

With three connected vehicles, the charging currents are further reduced to 20A. (Reserve 20A for offline charging stations)

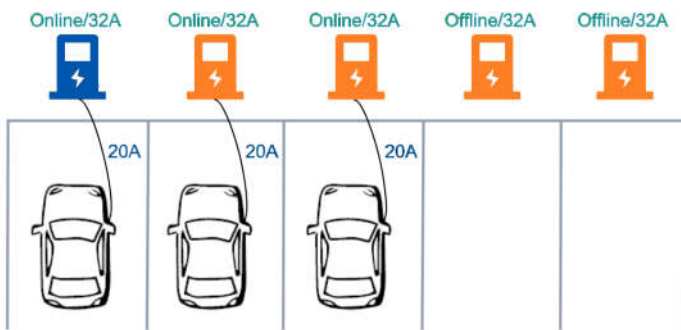

➤ **Priority mode (First Come First Serve)**

The available current is NOT divided equally amongst all available charging stations. The first vehicle connected would be allocated as much as possible. If any current capacity is left, then the remainder would be given to the other charging stations.

■ **Example 1**

In this example, there are three (32A) charging stations in the LLM group. Setting up each charging stations according to the following settings:

Setting	Gateway	Client
Local Load Management	Enable	Enable
Charging Policy	First In First Serve	Not used

Group ID	LLM-Group-1	LLM-Group-1 (Same as Gateway)
Group Size	3	Not used
Max Amperage Grid Connection	60	Not used
Fallback Current	10	10 (Same as Gateway)

The first vehicle connected would receive 32A.

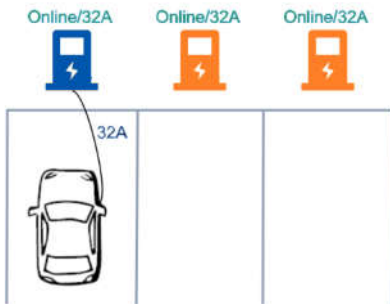

The second vehicle would receive 28A.

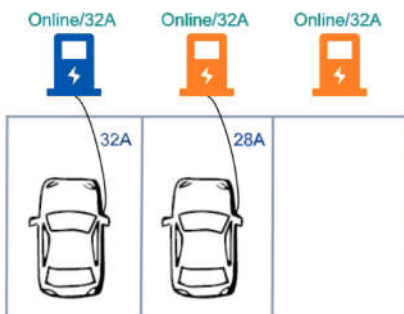

The third vehicle is NOT able to receive current.

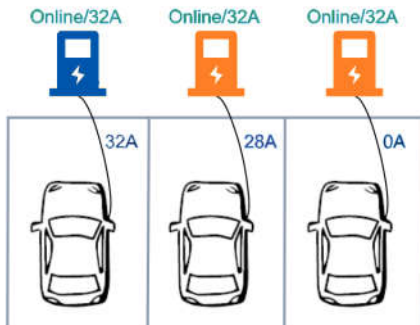

When the first vehicle left, the second vehicle would receive 32A, and the third vehicle would receive 28A.

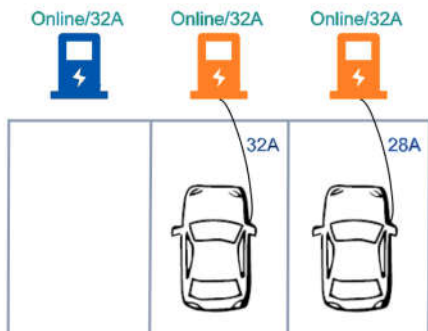

■ **Example 2**

In this example, there are five (32A) charging stations in the LLM group and two of the charging stations are offline. Setting up each charging stations according to the following settings:

Setting	Gateway	Client
Local Load Management	Enable	Enable
Charging Policy	First In First Serve	Not used
Group ID	LLM-Group-1	LLM-Group-1 (Same as Gateway)
Group Size	5	Not used
Max Amperage Grid Connection	100	Not used

Fallback Current	10	10 (Same as Gateway)
-------------------------	-----------	---------------------------------------

The first vehicle connected would receive 32A. (Reserve 20A for offline charging stations)



The second vehicle would receive 32A. (Reserve 20A for offline charging stations)

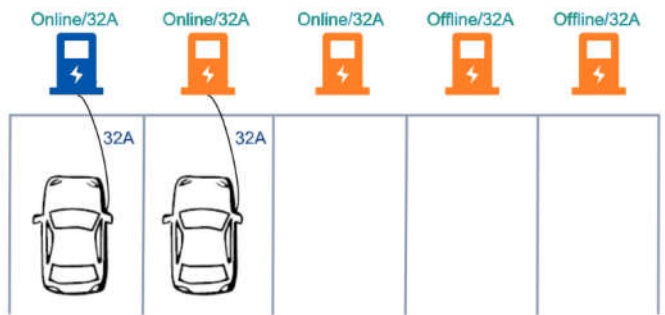

The second vehicle would receive 16A. (Reserve 20A for offline charging stations)

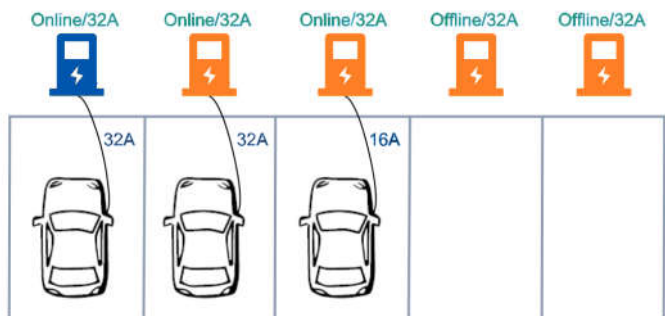

3.13 Security

3.13.1 Change password

To change password, first choose user you want to change password. There are two default users – **admin** and **maintain**. Only admin user can access Security Page. Enter old password and new password then press “**Apply**” button to change password of the user.

To reset password of all users, press “**Reset password of all users**” button.

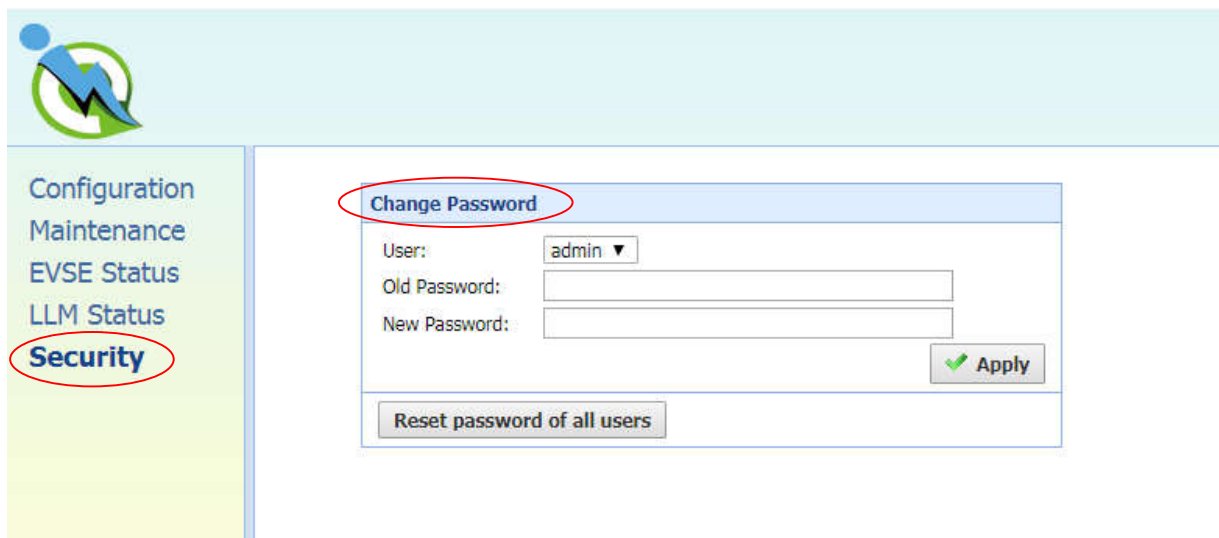





The screenshot shows a web interface with a sidebar on the left containing the following menu items: Configuration, Maintenance, EVSE Status, LLM Status, and Security. The 'Security' item is circled in red. The main content area displays a 'Change Password' form, also circled in red. The form has a title bar 'Change Password' and contains the following elements: a 'User:' dropdown menu with 'admin' selected, an 'Old Password:' text input field, a 'New Password:' text input field, an 'Apply' button with a green checkmark icon, and a 'Reset password of all users' button.

4 Operations

4.1 Charging status indicators

Table 4-1 Charging status indicators

LED Indicator	Description	Definition
	Not illuminated	Power Off
	Green Steady	Ready
	Green Flashing	Flashing green (Fast): Authorized, wait for EV Connect Flashing green (Slow): Suspend (Occupying)
	Blue Flashing	Flashing blue (Slow): Charging
	Red Steady	Unrecoverable Fault
	Red Flashing	Recoverable Fault
	Purple Steady	Reserved (from OCPP Service)
	Yellow Steady	Out of Service
	Yellow Flashing	Booting / Firmware Upgrading

4.2 Authorization (for IC3 only)

Before the owner of an electric vehicle can start or stop charging, the Charge Point has to authorize the operation.

4.2.1 Online Authorization

Description:

- Synchronized with the Central System when EVSE is Online.
- The EVSE SHALL only supply energy after authorization.

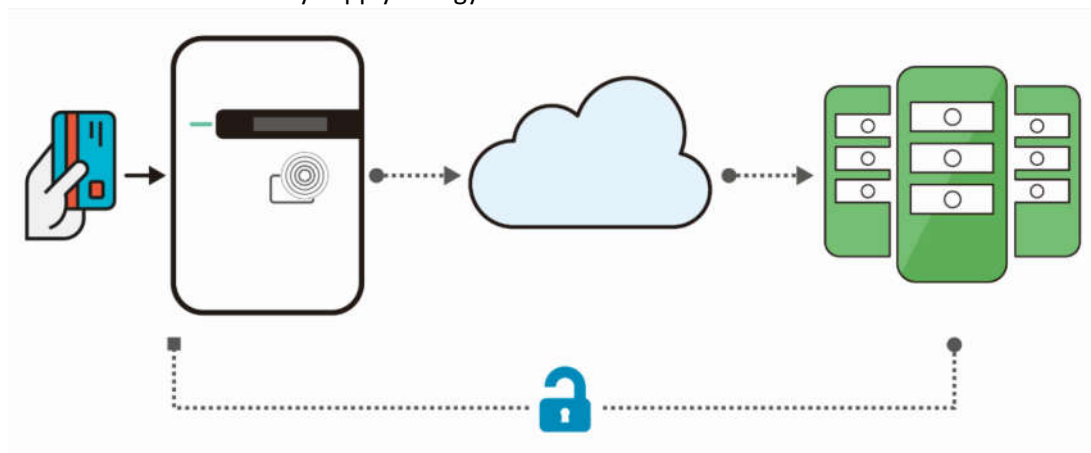

4.2.2 Local Authorization

Description:

- To improve the experience for users, the EVSE MAY support local authorization when EVSE is *offline*, and faster authorization response time when communication between Charge Point and Central System is slow.

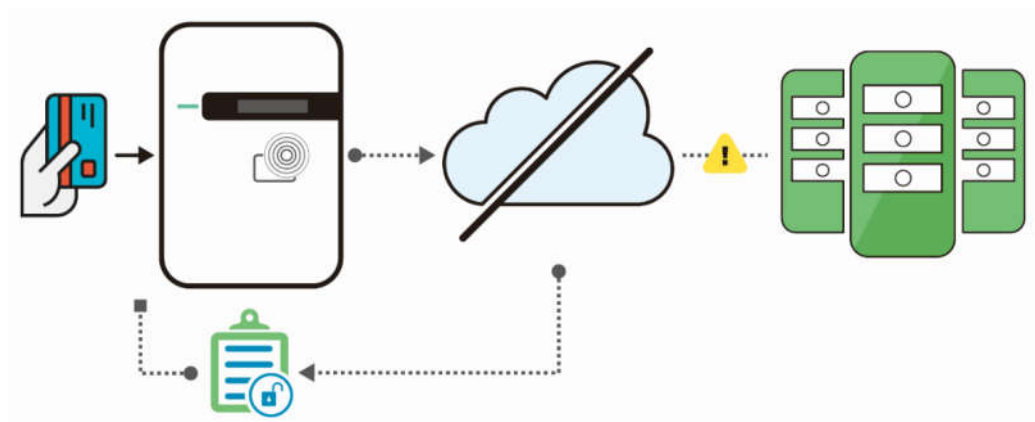

4.3 Charging an Electric Vehicle (EV)

Choices of start charging are as below:

4.3.1 Plug and Charge

1. Insert the charging plug into the EV
2. Charging session started

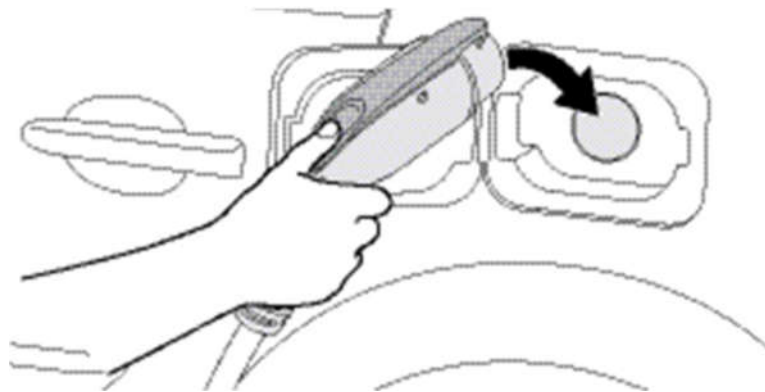

Figure 4-1 Connect the charging plug to the EV

4.3.2 RFID card (for IC3 only)

1. Insert the charging plug into the EV
2. Swipe card
3. Waiting for authorizing
4. Charging session started

4.4 Stop harging

1. Unplug any time (disconnect the charging plug from EV to stop charging session)
2. Session ended (please return the connector to the holster)

4.4.1 Interrupt charging

Please refer to STOP CHARGING section for more information.

4.4.2 Auto restart

When a charging session is interrupted due to a temporary error condition, the charge point will automatically restart charging when the cause of the temporary error condition returns to normal. Status indicator lights remain flashing RED until the error condition is resolved.

- Temporary error conditions include: Over Current, Over Voltage, Under Voltage, and Over Temperature.
- For Over Current conditions: The charging session will be stop while OC occurs. After recovery from OC for 30 seconds, the charge point will automatically restart charging for three times.
- When charging session stopped due to CCID trip, the charge point will try to restart after 15 minutes for 3 times.

4.4.3 Power outage recovery

When power resumes after an outage, the charge point restarts automatically with a delay ranging from 120 to 720 seconds. The delay is designed to avoid impacting the utility grid when multiple charge points are in the same area attempting to resume charging simultaneously.

4.5 General Care

The Blink charger features a rugged design that is rated for general outdoor use. To ensure proper maintenance of the charge point, follow these guidelines

- Despite the water resistance of the enclosure, when cleaning it is preferred to not direct streams of water at the unit. Clean with a soft, damp cloth.
- Make sure the charging plug is put back in the holster after charging to avoid damage.
- Ensure the power cable is stored on the charge point after use to avoid damage.
- If the power cable or the charging plug is damaged, please contact Customer Support.

4.6 Customer Support

Please contact your reseller directly for technical support.